



INSTALLATION MANUAL

TYPICAL ANTENNA

DOCUMENT NO. AYU5000

REVISION A



INSTALLATION MANUAL
Typical Antenna

Originator: _____

Approval: _____

Documentation Approval: _____



INTRODUCTION

This manual was created to be used as an installation aid for the operator.

For more detailed information about the hardware overview presented here, it is suggested that the user refer to the equipment manuals.

Advisories



WARNING

READ THIS ENTIRE MANUAL BEFORE BEGINNING ANY ACTIONS.

TO REDUCE THE RISK OF ELECTRICAL SHOCK, WATCH OUT FOR OVERHEAD POWER LINES. CHECK THE DISTANCE TO THE POWER LINES BEFORE STARTING THE INSTALLATION. STAY BACK A MINIMUM OF 6 METERS (20 FEET) FROM ALL POWER LINES.

DO NOT USE METAL LADDERS.

PERFORM AS MANY FUNCTIONS AS POSSIBLE ON THE GROUND.

IF YOU START TO DROP AN ANTENNA OR LOAD FRAME ASSEMBLY, GET AWAY FROM IT AND LET IT FALL.

IF ANY PART OF THE ANTENNA OR MAST ASSEMBLY COMES IN CONTACT WITH A POWER LINE, CALL YOUR LOCAL POWER COMPANY. DO NOT TRY TO REMOVE IT YOURSELF! THEY WILL REMOVE IT SAFELY.

MAKE SURE THAT THE LOAD FRAME IS PROPERLY GROUNDED.



CAUTION

Assembling dish antennas on windy days can be dangerous. Because of the antenna surface, even slight winds create strong forces. For example, a 1-meter antenna facing a wind of 32 km/h (20 mph) can undergo forces of 60 lbs. Be prepared to safely handle these forces at unexpected moments.



INSTALLATION MANUAL Typical Antenna

IMPORTANT SAFEGAURDS

Antennas improperly installed or installed to an inadequate structure are very susceptible to wind damage. The installer assumes full responsibility that the installation is structurally sound to support all loads (e.g., weight, wind, and ice) and properly sealed against leaks.

All non-penetrating roof mounts must have calculated wind load characteristics performed to ensure proper application. No site is to be installed without verifying that this process and associated information has been incorporated.



TABLE OF CONTENTS

1 SCOPE	1
2 APPLICABLE DOCUMENTS.....	1
3 PRE-INSTALLATION INFORMATION	2
3.1 SITE SELECTION.....	2
3.2 UNPACKING AND INSPECTION.....	2
4 INSTALLATION INFORMATION	3
4.1 NON-PENETRATING ROOF MOUNT ASSEMBLY (FOR 1.2-METER ANTENNAS)	3
4.1.1 <i>Mount Assembly Work Area</i>	3
4.1.2 <i>Mount Assembly Installation Tools and Equipment</i>	4
4.1.3 <i>Mount Assembly Instructions</i>	5
4.2 NON-PENETRATING ROOF MOUNT ASSEMBLY (FOR 1.8-METER ANTENNAS)	12
4.2.1 <i>Mount Assembly Work Area</i>	12
4.2.2 <i>Mount Assembly Installation Tools and Equipment</i>	13
4.2.3 <i>Mount Assembly Instructions</i>	14
4.2.4 <i>Ground Pole Installation</i>	21
4.3 1.2-METER CHANNELMASTER ANTENNA ASSEMBLY	22
4.3.1 <i>1.2 ChannelMaster Antenna Assembly Instructions</i>	23
4.4 1.8-METER CHANNELMASTER ANTENNA ASSEMBLY	28
4.4.1 <i>1.8 ChannelMaster Antenna Assembly Instructions</i>	29
4.5 ANTENNA POINTING AND PEAKING	35
4.6 CONNECTOR INSTALLATION	39
4.7 FEED COVER MODIFICATION.....	42
4.8 GROUNDING.....	43



LIST OF FIGURES

MOUNT ASSEMBLY - FIGURE 1	3
THREADED ROD ASSEMBLY - FIGURE 2.....	5
RECTANGULAR SUPPORT TUBE - FIGURE 3.....	5
RECTANGULAR SUPPORT ASSEMBLY - FIGURE 4.....	6
ANGLE CLAMP ASSEMBLY - FIGURE 5	6
BLOCK ASSEMBLY - FIGURE 6	7
MAST ASSEMBLY - FIGURE 7.....	8
LOWER MOUNT ANGLE ASSEMBLY - FIGURE 8	9
BRACE ANGLE AND LOWER MOUNT ANGLE ASSEMBLY - FIGURE 9	9
SECURING THE BLOCK ASSEMBLY - FIGURE 10.....	10
BRACE ANGLE ASSEMBLY - FIGURE 11	11
MOUNT ASSEMBLY - FIGURE 12.....	12
LOWER MAST ASSEMBLY - FIGURE 13	14
BRACE ANGLE - FIGURE 14.....	15
BRACE ANGLE/ARM TUBE ASSEMBLY - FIGURE 15.....	16
THREADED ROD ASSEMBLY - FIGURE 16.....	17
THREADED ROD AND ARM TUBE ASSEMBLY - FIGURE 17	17
ANGLE CLAMP ASSEMBLY - FIGURE 18	18
BLOCK ASSEMBLY - FIGURE 19.....	19
MAST ASSEMBLY - FIGURE 20.....	19
SECURING THE BLOCK ASSEMBLY - FIGURE 21	20
FOUNDATION DIAGRAM - FIGURE 22	21
AZ/EL HOUSING EXPLODED DIAGRAM - FIGURE 23.....	23
1.2-METER REFLECTOR ASSEMBLY - FIGURE 24.....	24
AZ/EL ASSEMBLY - FIGURE 25	25
FEED & STRUT ASSEMBLY - FIGURE 26.....	26
LNB ASSEMBLY - FIGURE 27	27
AZ/EL BACKFRAME ASSEMBLY EXPLODED DIAGRAM - FIGURE 28	30
AZ/EL BACKFRAME ASSEMBLY - FIGURE 29	31
1.8-METER ANTENNA ASSEMBLY - FIGURE 30.....	32
FEED & STRUT ASSEMBLY - FIGURE 31.....	33
LNB ASSEMBLY - FIGURE 32	34
POLARIZATION OF THE FEED - FIGURE 33	36
ELEVATION ADJUSTMENT - FIGURE 34	37
AZIMUTH ADJUSTMENT - FIGURE 35.....	38
TRIMMING RG11 CABLE - FIGURE 36.....	39
CRIMPING RG11 CABLE - FIGURE 37	40
WEATHER SEALING RG11 CABLE - FIGURE 38.....	41
TYPICAL ANTENNA GROUND - FIGURE 39.....	43
GAS TUBE ARRESTORS - FIGURE 40.....	43



1 SCOPE

This manual provides a systematic methodology for typical antenna installations.

It covers 1.2 and 1.8-meter reflectors attached to a modular AZ/EL housing assembly optimized for fixed positioning on geostationary satellites. The elevation adjustment is continuous from 0 to 75 degrees. The azimuth adjustment is capable of a full 360-degree rotation.

The AZ/EL housing is designed to fit over and clamp tightly to a 3" outer diameter pipe or mast when the reflector is 1.2-meters and a 4.5" outer diameter pipe when the reflector is 1.8-meters. The pipe or mast is attached to a hot-dipped galvanized steel mount assembly constructed of steel components assembled into a non-penetrating load frame designed to support and spread the ballast weights and counter wind loading effects.

The frame is required to be constructed over a protection and friction enhancing substrate due to the functional design requirements of the load frame. The substrate, usually rubber, lies between the load surface that the system is being erected on and the mount components that will be in contact with that surface. In some applications, it may be necessary to ground mount the antenna or install using a wall mount. The former being a pipe embedded in a concrete foundation, and the latter being a pipe and bracket assembly affixed to a relatively vertical structure.

The antenna is comprised of two functional sub-components: the reflector (which is of a surface design to be aimed and consequently reflect signals to a predetermined focus), and a feed mechanism (which collects the reflected signals). The reflector employed here is an offset antenna of a transmit compatible, type-accepted manufacture. The fielded feed mechanism is dual port, receive-only universal wideband design. The feed support assembly is comprised of a three-leg strut system attached to the perimeter of the reflector and extending out to the offset focal point. The feed and ancillary components are attached to this vertex plate.

2 APPLICABLE DOCUMENTS

Feed Cover Installation Procedure (Form Number F023).

Site Survey Manual (Document Number SUP345).

Missing Materials Worksheet (Form Number F047).

RMA Process Sheet (Form Number F057).

Ground Pole Installation Worksheet (Form Number F089).



3 PRE-INSTALLATION INFORMATION

This chapter details information that will be needed by the engineer before installing the outdoor equipment.

3.1 Site Selection

A site survey will need to be completed in advance. The site survey is covered in the *Field Services Site Survey Manual (Document Number SUP345)*. In general, the site selected will provide an unobstructed southward view of the satellite(s) of interest. Occasionally, a considerable amount of time will elapse between the survey and the commencement of the equipment installation. In those cases, it will be necessary to ascertain whether or not the view has been obstructed due to unforeseen changes. Additionally, some radio or terrestrial interference may be present that could adversely impact the installation. Due to the transient nature of interference, it would be wise to keep the possible existence of it in mind when working on-site.

3.2 Unpacking and Inspection

Inspect each crate and packed unit for visible damage. Note any visible crate damage on the freight bill or receipt, and have it signed by the carrier's agent. Failure to adequately describe such external evidence of loss or damage may result in the carrier refusing to honor a damage claim. Request a damage claim ticket from the carrier and fill it out.

In the event of a damaged unpacked unit, make a written request for inspection by the carrier's agent within 15 days of the delivery date. File a claim with the carrier since such damage is the carrier's responsibility.

The packing slip is to be used as confirmation of materials received and should be cross-checked between the specific installation needs and the materials shipped. The packing slip should be faxed back to Technical Support at the earliest possible moment.

Should any parts be damaged, mismatched, or missing, send the bad parts along with the appropriate forms to Technical Support. Technical Support has forms specifically for reporting missing equipment and for returning bad equipment.

Finally, all waste materials must be properly disposed of after all installation work has been completed.



4 INSTALLATION INFORMATION

This chapter details information that will be needed by the engineer to install the outdoor equipment.

4.1 Non-penetrating Roof Mount Assembly (For 1.2-Meter Antennas)

The Mount Assembly can be used for the entire domestic satellite arc and does not require orientation on the center of the satellite arc. However, to ensure proper calculated wind loading characteristics, the mount should be oriented at an azimuth angle that will accommodate viewing the satellite of interest. The Mount Assembly is shown in Figure 1.

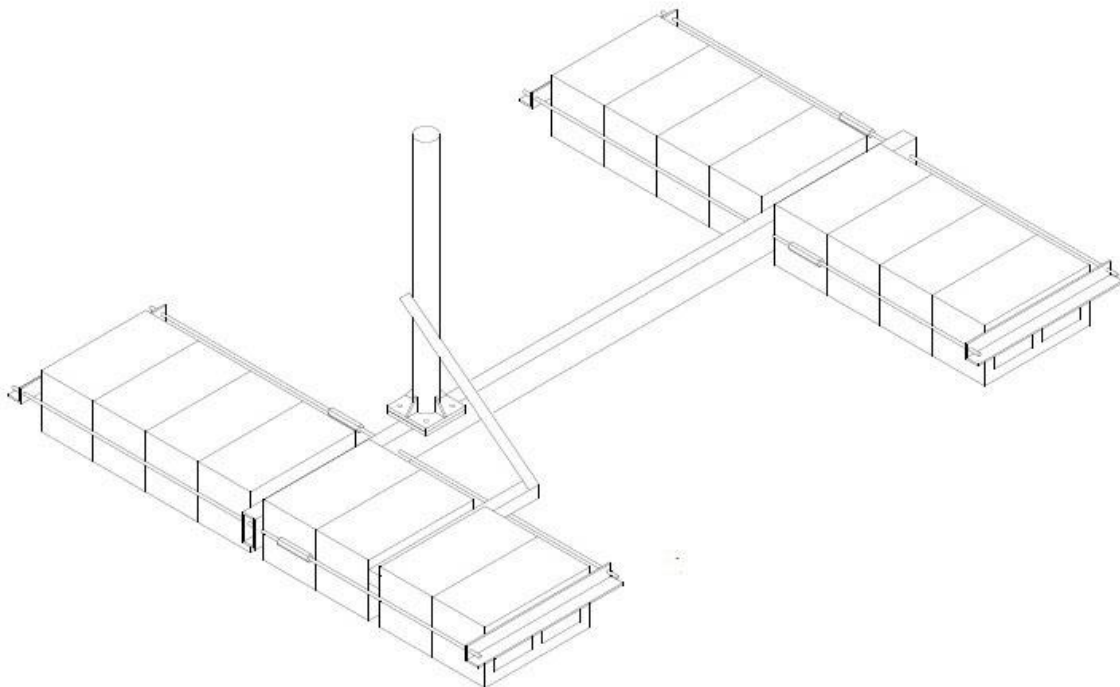

Mount Assembly
Figure 1

4.1.1 Mount Assembly Work Area

The work area should provide plenty of space for pre-assembly and assembly activity. Before beginning, clear the area of debris, rock, ballast, dust, sand, and standing water. Sweep the area with a broom to remove any loose materials.

Using the typical mount size footprints as a guide, place the provided substrate textured side down on the previously cleared installation area. Be sure the layout is oriented as appropriate for the satellite of interest.



INSTALLATION MANUAL
Typical Antenna

4.1.2 Mount Assembly Installation Tools and Equipment

This section lists all tools and equipment necessary for the Mount Assembly installation. Table 1 lists the tools that the Field Service Engineer should have on hand. Table 2 lists the equipment that should be included in the delivered installation package.

The Mount Assembly is designed to capture and clamp various quantities of 32-pound concrete ballast blocks using angle brackets and threaded rods. The ballast is usually composed of 2 rows of 8 to 16 blocks (each row) depending on the previously calculated site wind load characteristics. Table 3 shows the correlation between threaded rod lengths, number of concrete blocks, and pressure pads.

Tools	
12" Adjustable Wrench	Level
5/8" Open End Wrench	Felt Marker
2 Qty - 3/4" Open or Box End Wrench	Tape Measure

Field Service Tools
Table 1

P/N	Qty	Description
19	1	Rectangular Support Tube
18	4	Short Threaded Rods (see Table 3)
17	4	Long Threaded Rods (see Table 3)
16	4	Threaded Rod Couplers
15	4	Clamp Angles .18"x 2" x 2" by 17.08"
14	16	3/8" Coupler Nuts for Clamp Angles
13	8	3/8" Lockwashers for Clamp Angles
12	8 to 16	Concrete Blocks per Row (see Table 3)
11	2	Pressure Pads (see Table 3)
10	1	3.0" Outer Diameter Mast
9	4	1/2" x 1.25" Bolts for Mast
8	4	1/2" Lockwashers for Mast
7	4	1/2" Nuts for Mast
6	1	Lower Mounting Angle 1.75" x 1.75" x 19"
5	1	Brace Angle .12" x 1.5" x 1.5" by 22.3"
4	1	3/8" x 4" Bolt for Brace Angle
3	1	3/8" Flatwasher for Brace Angle
2	2	3/8" Whizlock Nuts for Lower Mounting and Brace Angles
1	1	3/8" x 1.00" Bolt for Lower Mounting and Brace Angles

Mount Assembly Installation Equipment
Table 2

# of Blocks per Row	Threaded Rods Short & Long	Pressure Pads
8	3/8" x 18" 3/8" x 48"	18" x 68"
10	3/8" x 24" 3/8" x 60"	18" x 81"
12	3/8" x 38" 3/8" x 60"	18" x 98"
14	3/8" x 46" 3/8" x 72"	18" x 112"
16	3/8" x 60" 3/8" x 72"	18" x 83"

Threaded Rods and Pressure Pads
Table 3



4.1.3 Mount Assembly Instructions

This section shows the steps required to assemble the Mount. The part numbers are shown in parentheses.

1. Utilizing the appropriate threaded rods required for the number of blocks, assemble each short length (18) with a long length (17) using the threaded rod coupler (16) to join them (see Figure 2). You should have 4 threaded rod assemblies when done.

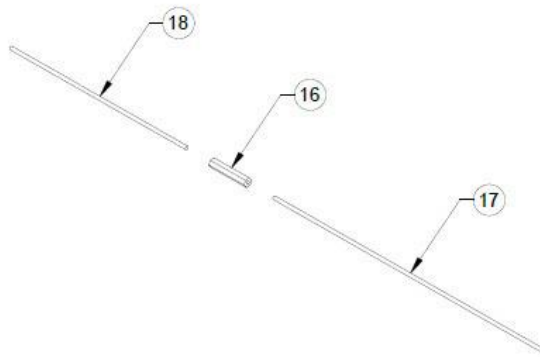

Threaded Rod Assembly
Figure 2

2. Place the rectangular support tube (19) on the ground with the 6" x 6" mast plate facing up (see Figure 3). Orient the support tube in the azimuth heading of the satellite of interest. The mast plate should be facing up and toward the leading edge of the azimuth heading.

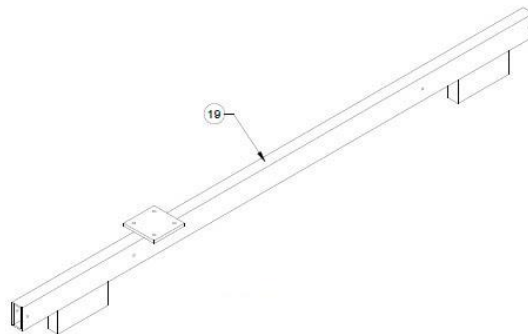

Rectangular Support Tube
Figure 3



INSTALLATION MANUAL Typical Antenna

3. Insert a threaded rod, long end first (17), through the first pre-drilled hole in the rectangular support tube (see Figure 4). Step across the rectangular support tube and insert another rod, long end first, through the second pre-drilled hole. The idea is to stagger the coupler on opposite sides of the rectangular support tube for stability.

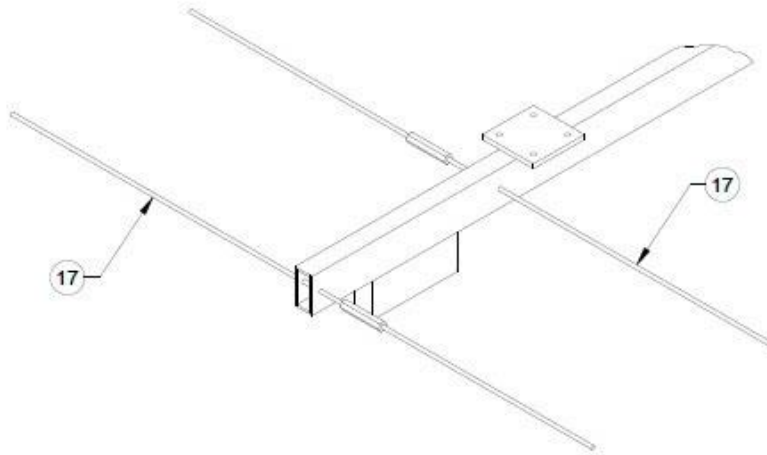

Rectangular Support Assembly
Figure 4

4. Slide an angle clamp (15), face down and outward, on both ends of the rods by aligning the pre-drilled holes with the threaded rods (see Figure 5). Install the angle clamp with a 3/8" lockwasher (13) against the clamp and a 3/8" coupler nut (14), but do not tighten.

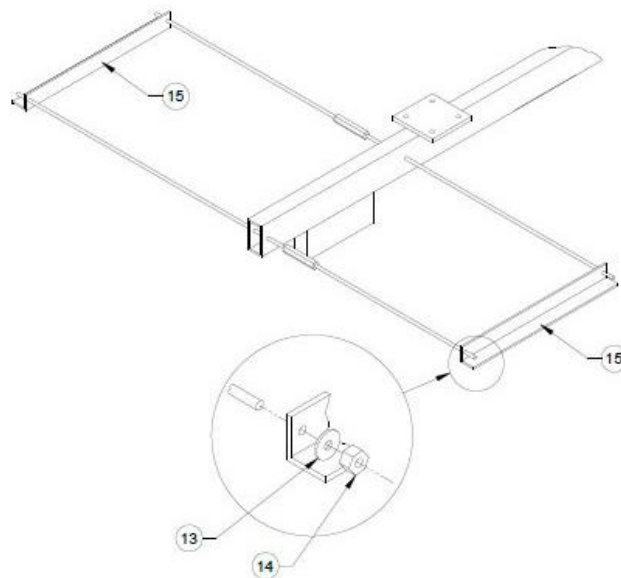

Angle Clamp Assembly
Figure 5



INSTALLATION MANUAL Typical Antenna

5. Repeat the assembly process for the other side of the rectangular support tube starting with step 3.
6. Place the pressure pads (11) on the ground under the angle clamp assemblies. Center the pads using the threaded rods and clamp angles as guides.
7. Place the appropriate number of concrete blocks (12) between all threaded rods and clamps. The long axes of the blocks should be perpendicular to the threaded rods (see Figure 6). Square up the assembly, but do not tighten the coupler nuts. Repeat the process on the other side of the rectangular support tube.

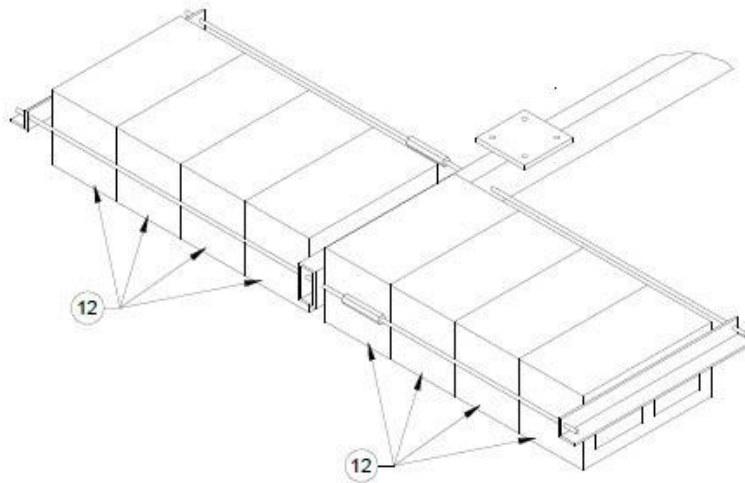

Block Assembly
Figure 6

8. Attach the mast (10) using the four supplied 1/2" x 1.25" bolts (9), 1/2" nuts (7), and 1/2" lockwashers (8). Insert the bolts from the bottom up placing the lockwasher between the nut and the top of the mast plate (see Figure 7). Tighten the mast bolts until the lockwasher is fully collapsed and is properly tightened.



INSTALLATION MANUAL
Typical Antenna

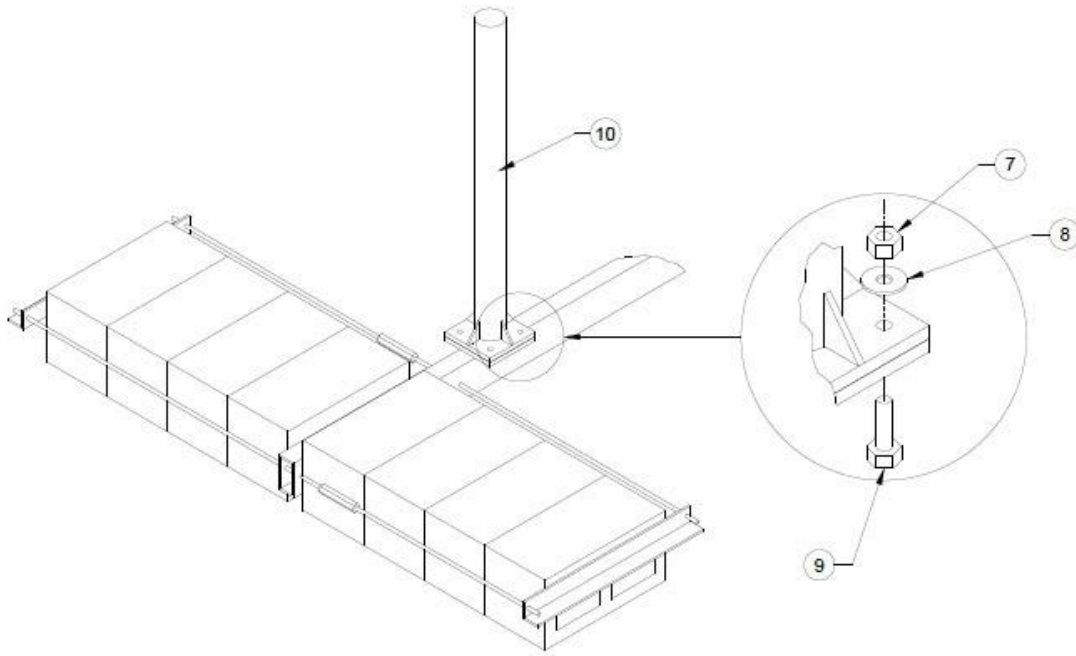

Mast Assembly
Figure 7



INSTALLATION MANUAL Typical Antenna

9. Facing the concrete blocks closest to the mast, insert the lower mount angle (6) between the second and third blocks from the support tube on the right side (see Figure 8).

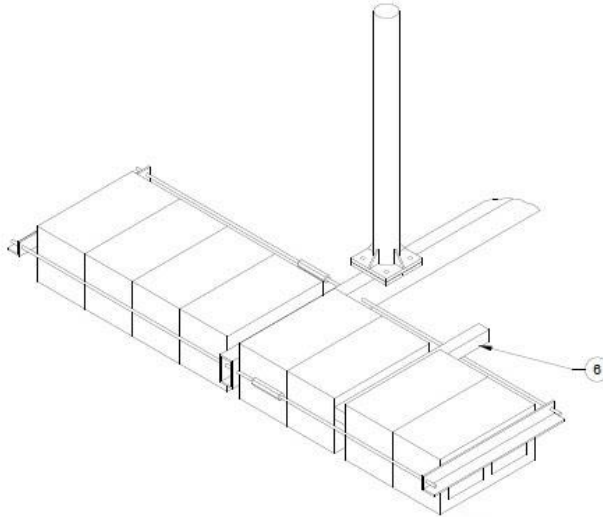

Lower Mount Angle Assembly
Figure 8

10. Attach the brace angle (5) to the mast using the supplied 3/8" x 4" bolt (4), 3/8" flatwasher (3), and 3/8" whizlock nut (2), but do not tighten. Dry fit the brace angle to the lower mount angle (6), but do not bolt together (see Figure 9).

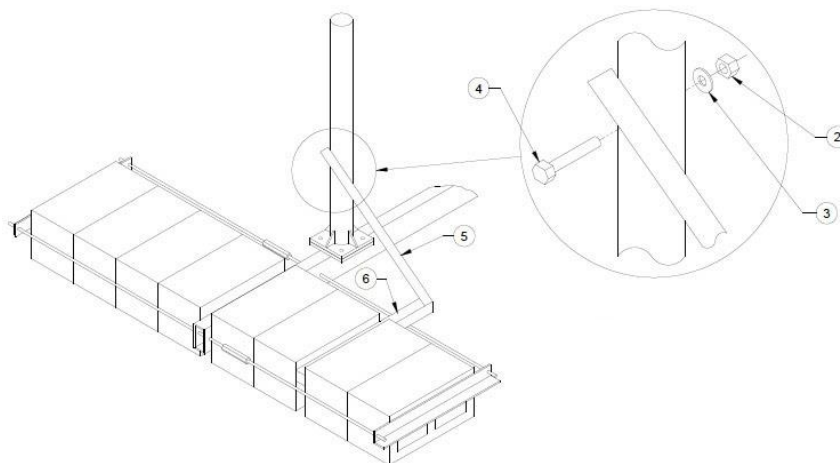

Brace Angle and Lower Mount Angle Assembly
Figure 9



INSTALLATION MANUAL Typical Antenna

11. Secure the block assembly by tightening the coupler nuts (14) on the clamp angles starting with the coupler nut closest to the threaded rod coupler (see Figure 10). Tighten and torque to 25 ft/lbs. Tighten the remaining coupler nuts in the entire assembly by working in a diagonal pattern for each side. If the rod turns, use the double nut method (shown in the circle) to keep the rod from spinning. Eight extra 3/8" coupler nuts were provided in the installation kit for the double nut method.

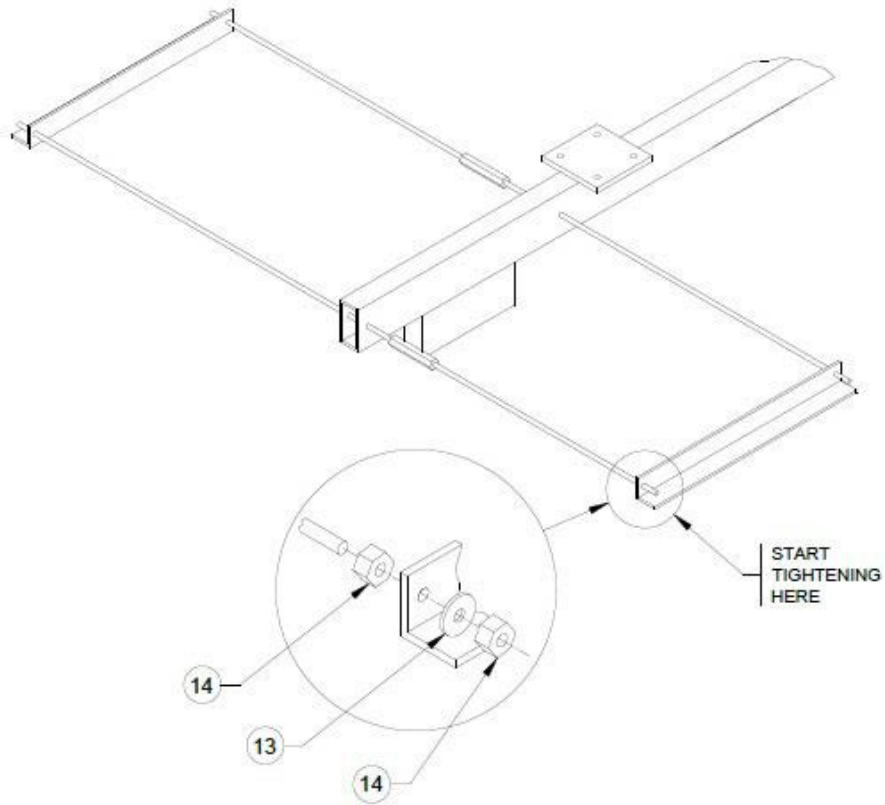

Securing the Block Assembly
Figure 10



INSTALLATION MANUAL Typical Antenna

12. Firmly attach the brace angle (5) to the lower mount angle (6) using the 3/8" x 1.00" bolt (1) and 3/8" whizlock nut (2). Tighten the brace angle at the mast (see Figure 11).

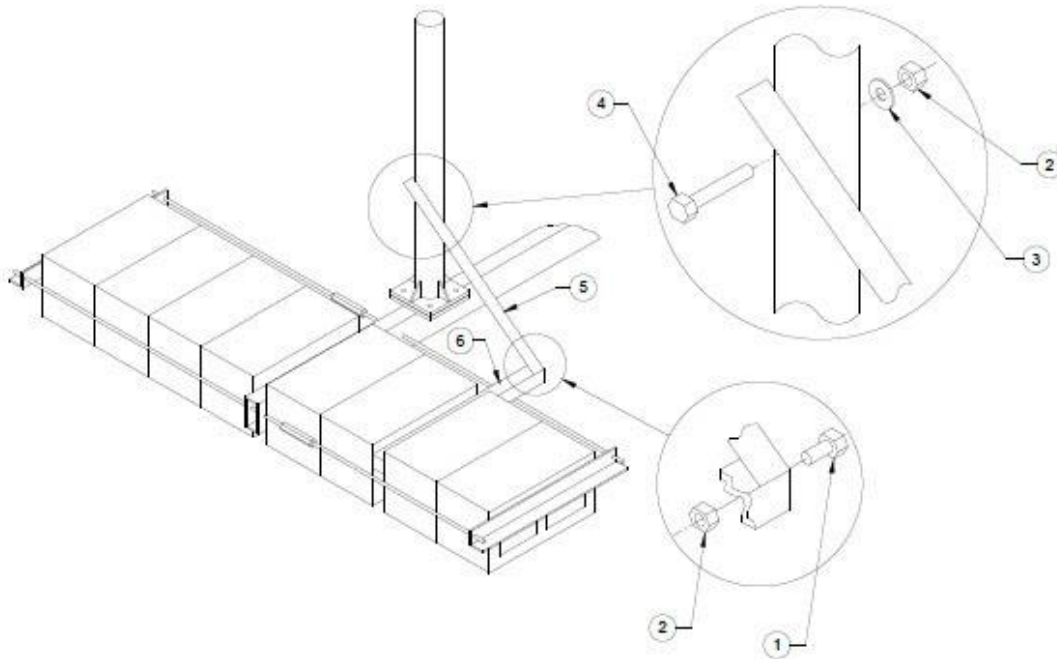

Brace Angel Assembly
Figure 11



4.2 Non-penetrating Roof Mount Assembly (For 1.8-Meter Antennas)

The Mount Assembly can be used for the entire domestic satellite arc and does not require orientation on the center of the satellite arc. However, to ensure proper calculated wind loading characteristics, the mount should be oriented at an azimuth angle that will accommodate viewing the satellite of interest. The Mount Assembly is shown in Figure 12.

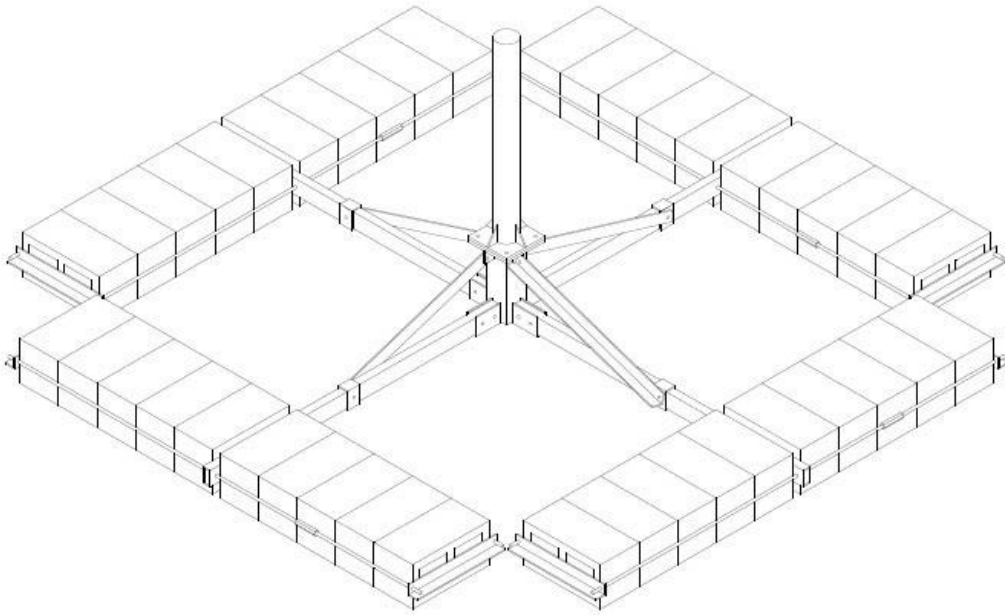

Mount Assembly
Figure 12

4.2.1 Mount Assembly Work Area

The work area should provide plenty of space for pre-assembly and assembly activity. Before beginning, clear the area of debris, rock, ballast, dust, sand, and standing water. Sweep the area with a broom to remove any loose materials.

Using the typical mount size footprints as a guide, place the provided substrate textured side down on the previously cleared installation area. Be sure the layout is oriented as appropriate for the satellite of interest.



INSTALLATION MANUAL
Typical Antenna

4.2.2 Mount Assembly Installation Tools and Equipment

This section lists all tools and equipment necessary for the Mount Assembly installation. Table 4 lists the tools that the Field Service Engineer should have on hand. Table 5 lists the equipment that should be included in the delivered installation package.

The Mount Assembly is designed to capture and clamp various quantities of 32-pound concrete ballast blocks in 2 axes using angle brackets and threaded rods. The ballast is usually composed of 4 rows of 6 to 12 blocks (each row) depending on the previously calculated site wind load characteristics. Table 6 shows the correlation between threaded rod lengths, number of concrete blocks, and pressure pads.

Tools	
12" Adjustable Wrench	Level
5/8" Open End Wrench	Felt Marker
2 Qty - 3/4" Open or Box End Wrench	Tape Measure

Field Service Tools
Table 4

P/N	Qty	Description
24	1	Lower Mast Base
23	8	Short Threaded Rods (see Table 6)
22	8	Long Threaded Rods (see Table 6)
21	8	Threaded Rod Couplers
20	8	Clamp Angles .18"x 2" x 2" by 17.08"
19	32	3/8" Coupler Nuts for Clamp Angles
18	16	3/8" Lockwashers for Clamp Angles
17	6 to 12	Concrete Blocks Per Row (see Table 6)
16	4	Pressure Pads (see Table 6)
15	1	4.5" Outer Diameter Mast
14	4	5/8" x 2" Bolts for Mast
13	4	5/8" Lockwashers for Mast
12	4	5/8" Nuts for Mast
11	4	Arm Tubes
10	8	.5" x 2.25" Bolts for Arm Tubes
9	8	.5" Lockwashers for Arm Tubes
8	8	.5" Nuts for Arm Tubes
7	4	Brace Angles .12" x 1.5" x 2" by 35.75"
6	4	.5" x 2.25" Bolts for Brace Angles and Arm Tubes
5	4	.5" Lockwashers for Brace Angles and Arm Tubes
4	4	.5" Nuts for Brace Angles and Arm Tubes
3	4	.5" x 1.25" Bolts for Brace Angles and Lower Mast Base
2	4	.5" x 1.25" Lockwashers for Brace Angles and Lower Mast Base
1	4	.5" x 1.25" Nuts for Brace Angles and Lower Mast Base

Mount Assembly Installation Equipment
Table 5

# of Blocks per Row	Threaded Rods Short & Long	Pressure Pads
6	3/8" x 16" 3/8" x 36"	16" x 51"
8	3/8" x 18" 3/8" x 48"	16" x 66"
10	3/8" x 24" 3/8" x 60"	16" x 81"
12	3/8" x 36" 3/8" x 60"	16" x 96"

Threaded Rods and Pressure Pads
Table 6



4.2.3 Mount Assembly Instructions

This section shows the steps required to assemble the Mount. The part numbers are shown in parentheses.

1. Place the lower mast base (24) on the ground with the 6" x 6" plate facing upward. Align the bolt holes in the four arm tubes (11) to the lower mast base by sliding the cantilevered end between the lower plates. Be sure that the pedestal end on each arm is facing downward. Attach the lower mast base to the arm tubes with the .5" x 2.25" bolts (10), .5" lockwashers (9), and .5" nuts (8). Be sure that the lockwasher is placed on the nut side of the bolt (see Figure 13), but do not tighten.

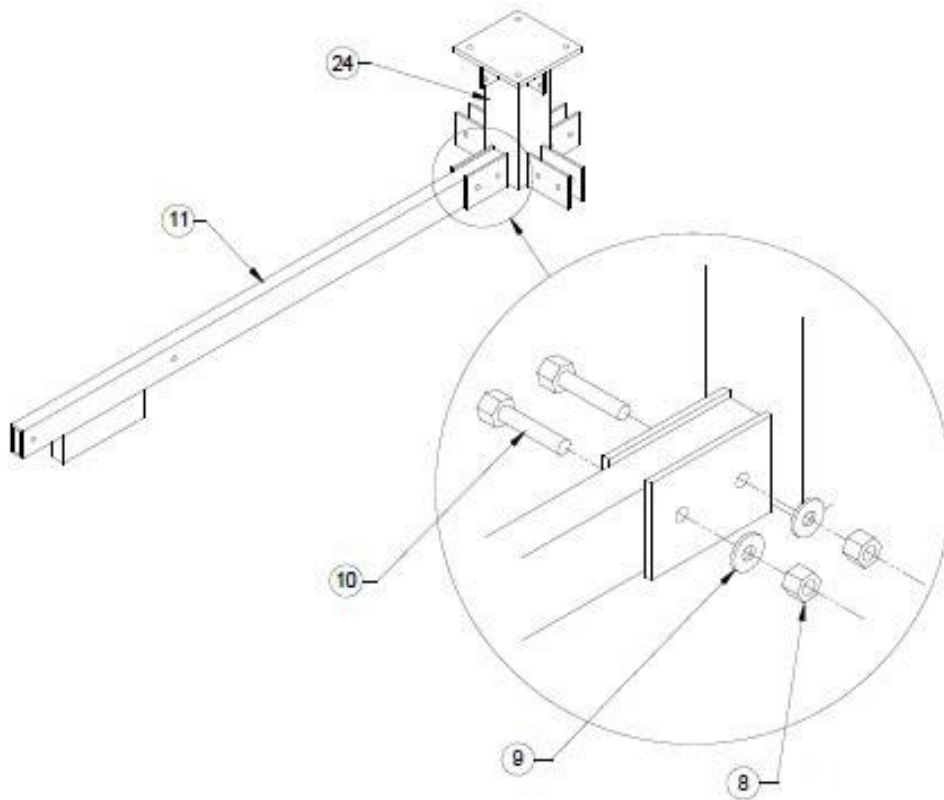

Lower Mast Assembly
Figure 13



INSTALLATION MANUAL Typical Antenna

2. Attach the four brace angles (7) to the 6" x 6" plate on the lower mast base (24) with the .5" x 1.25" bolts (3), .5" nuts (1), and .5" lockwashers (2). Be sure that the brace angles are facing downward (see Figure 14). Place the lockwasher on the nut side of the bolt, but do not tighten.

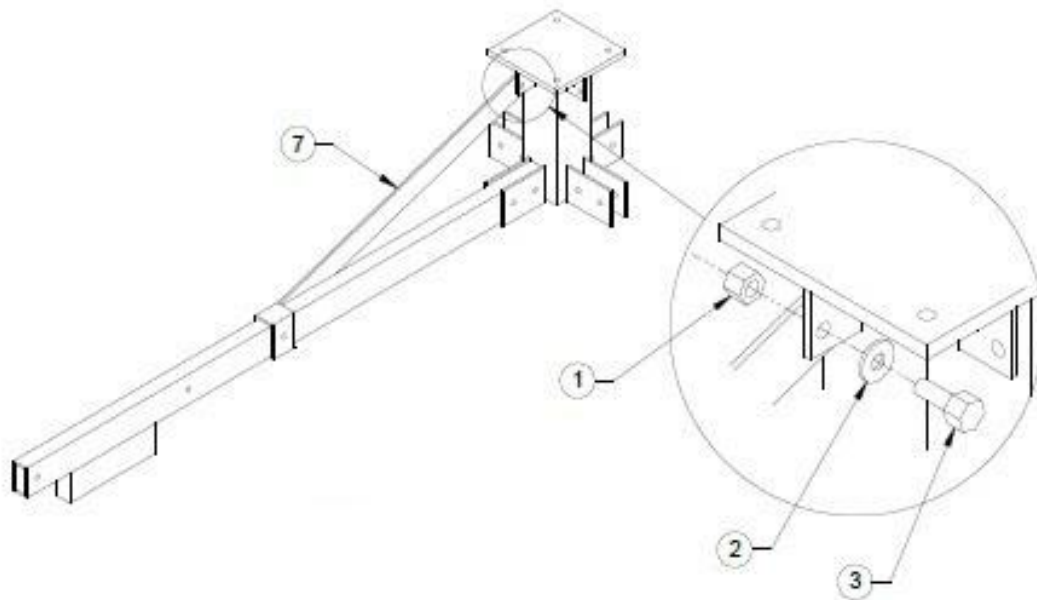

Brace Angle
Figure 14



INSTALLATION MANUAL Typical Antenna

3. Attach the four brace angles to the arm tubes with the .5" x 2.25" bolts (6), .5" nuts (4), and .5" lockwashers (5). Place the lockwasher on the nut side of the bolt (see Figure 15), but do not tighten.

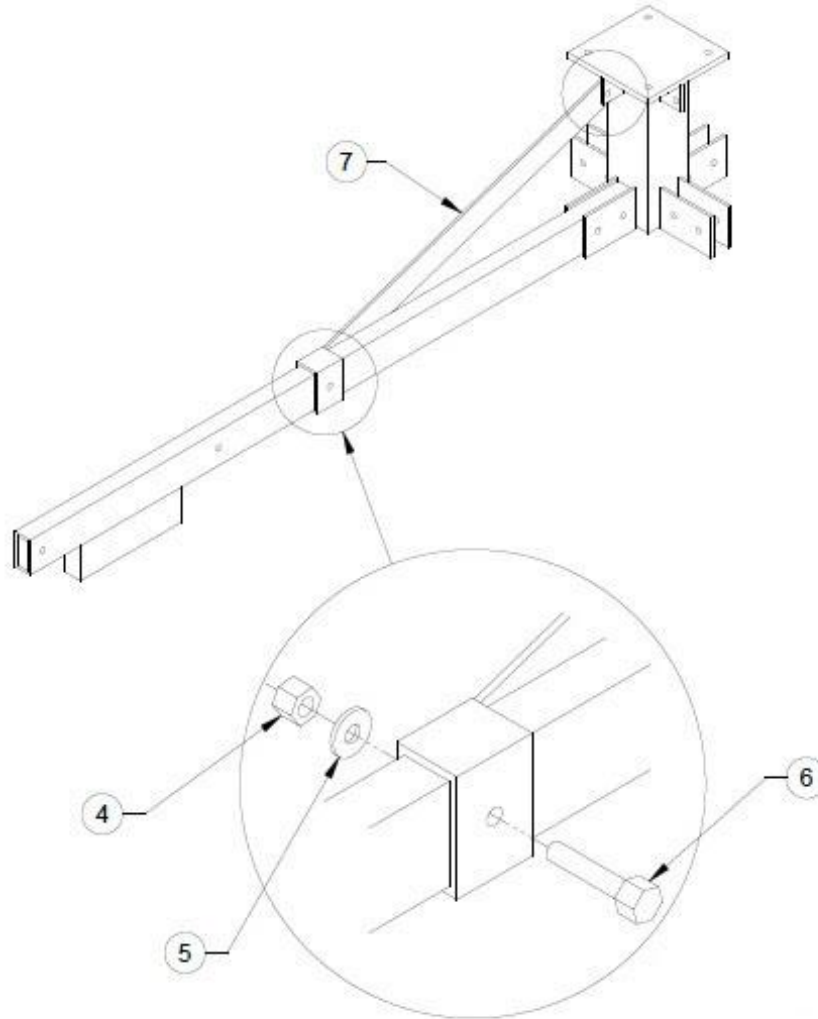

Brace Angle/Arm Tube Assembly
Figure 15



INSTALLATION MANUAL Typical Antenna

- Utilizing the appropriate threaded rods required for the number of blocks, assemble each short length (23) with a long length (22) using a threaded rod coupler (21) to join them (see Figure 16). You should have 8 threaded rod assemblies.

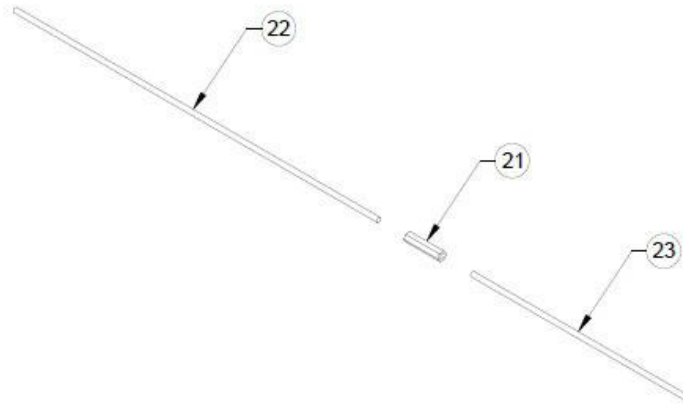

Threaded Rod Assembly
Figure 16

- Insert a threaded rod, long end first (22), through the first pre-drilled hole in the arm tube (see Figure 17). Step across the arm tube and insert another rod, long end first (22), through the second pre-drilled hole. The idea is to stagger the coupler on opposite sides of the arm tube for stability.

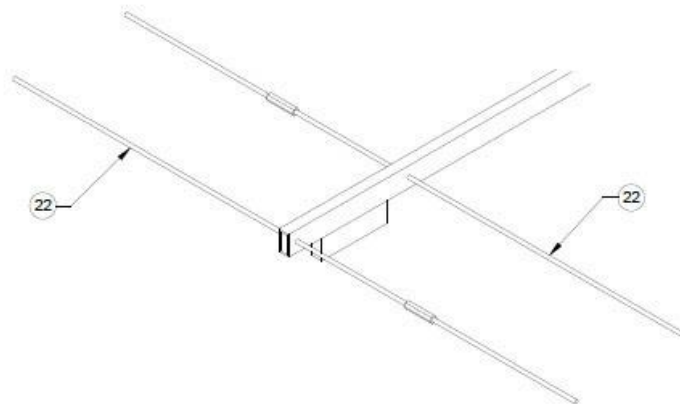

Threaded Rod and Arm Tube Assembly
Figure 17



INSTALLATION MANUAL Typical Antenna

6. Orient the assembly so that the arm tubes in one direction are in the azimuth heading of the satellite of interest. The other arm tubes will consequently align at 90 degrees.
7. Slide an angle clamp (20), face down and outward, on the end of the rods by aligning the pre-drilled holes with the threaded rods (see Figure 18). Install the angle clamp with a 3/8" lockwasher (18) (against the clamp) and a 3/8" coupler nut (19), but do not tighten.

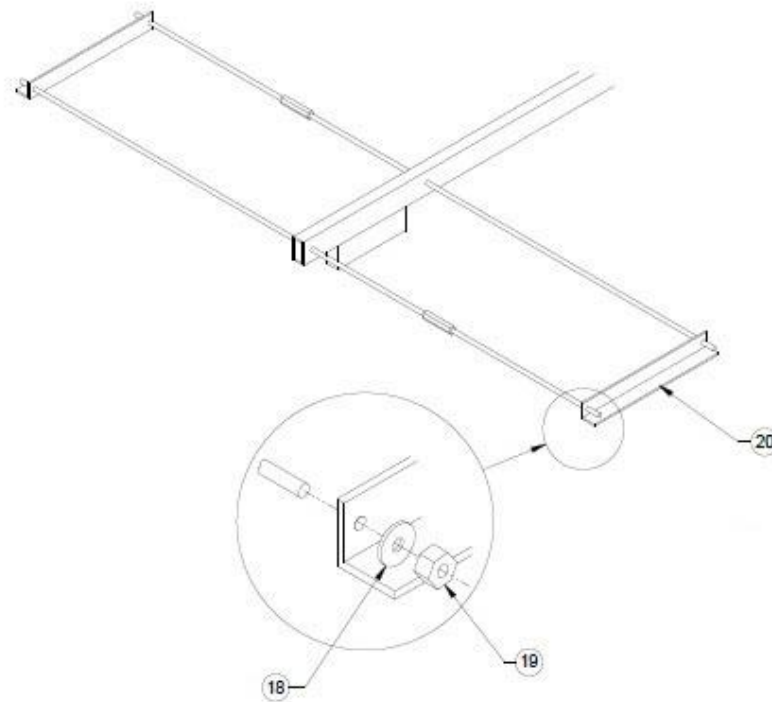

Angle Clamp Assembly
Figure 18

8. Repeat the assembly process for the remaining arm tubes (11) starting with step 5.
9. Place the pressure pads (16) on the ground under the assembly. Center the pad using the threaded rods and clamp angles as guides.
10. Place the appropriate number of concrete blocks (17) between all threaded rods and clamps. The long axes of the blocks should be perpendicular to the threaded rods (see Figure 19). Square up the assembly, but do not tighten the coupler nuts.



INSTALLATION MANUAL

Typical Antenna

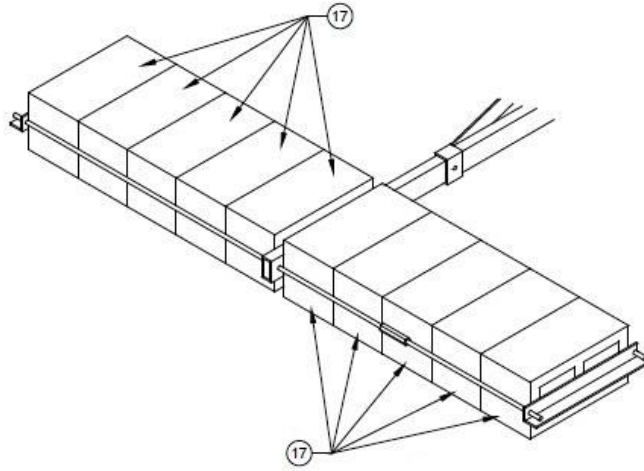

Block Assembly
Figure 19

11. Attach the mast (15) using the four supplied 5/8" x 2" bolts (14), 5/8" nuts (12), and 5/8" lockwashers (13). Insert the bolts from the bottom up placing the lockwasher between the nut and the top of the mast plate (see Figure 20). Tighten the mast bolts until the lockwasher is fully collapsed and is properly tightened.

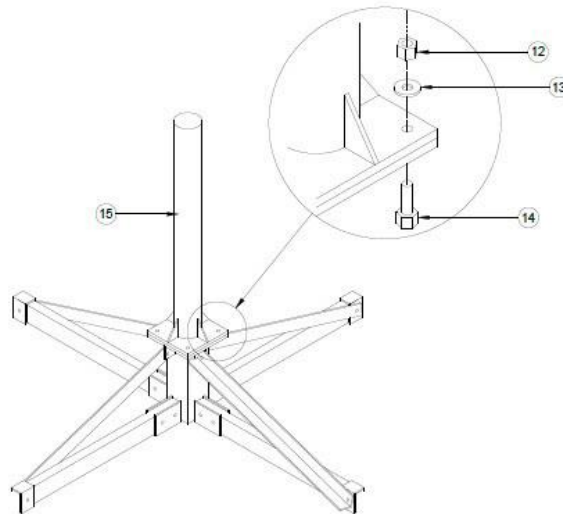

Mast Assembly
Figure 20



INSTALLATION MANUAL Typical Antenna

- Secure the block assembly by tightening the coupler nuts (19) on the clamp angles (20) starting with the coupler nut closest to the threaded rod coupler (see Figure 21). Tighten and torque to 25 ft/lbs. Tighten the remaining coupler nuts by working in a diagonal pattern. If the rod turns, use a double nut method (shown in the circle) to keep the rod from spinning. Tighten all remaining hardware.

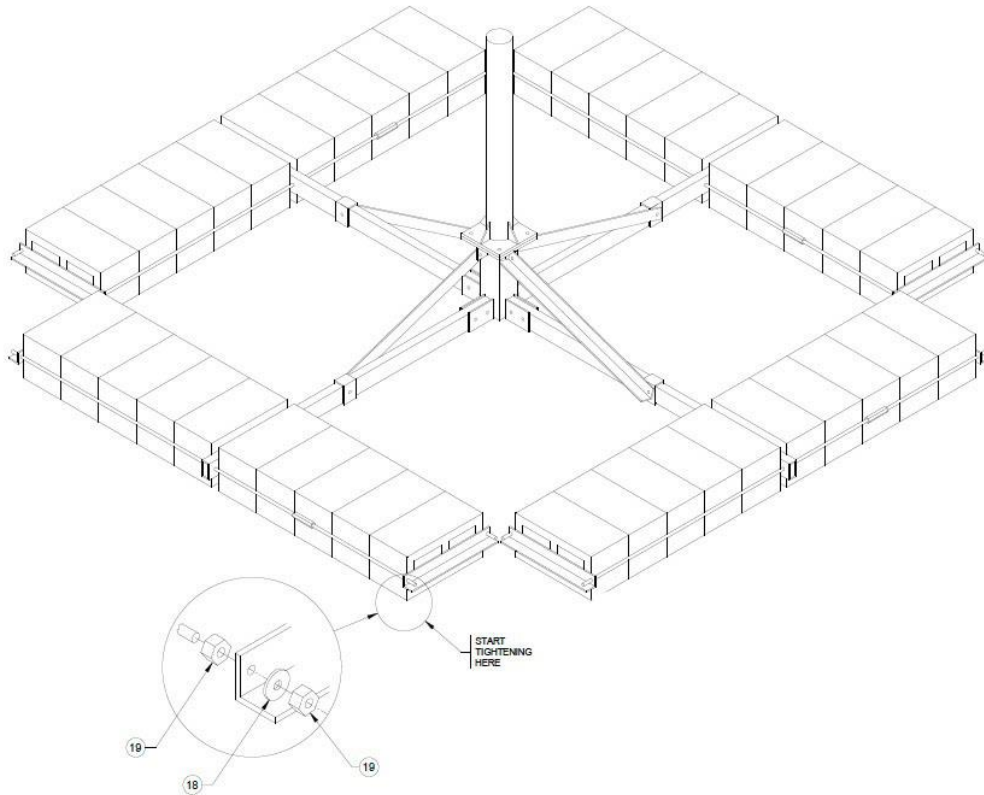

Securing the Block Assembly
Figure 21



4.2.4 Ground Pole Installation

This section explains the procedure for installing a ground pole.

Pole Specifications

1. For a 1.2-Meter ChannelMaster reflector, use a 3" outer diameter x .218 wall (Sched 80) x 72" long galvanized steel pole.
2. For a 1.8-Meter ChannelMaster reflector, use a 4.5" outer diameter x .218 wall (Sched 80) x 72" long galvanized steel pole.

Pole and Foundation Criteria

1. The pole and foundation design is based on the following:
 - a. Uniform Building Code Exposure C and 1.5 stability factor.
 - b. Vertical soil pressure of 2000 pounds per square foot.
 - c. Lateral soil pressure of 400 pounds per square foot.
 - d. Concrete compressive strength of 2500 pounds per square inch in 28 days.

Figure 22 is intended to be used only as a reference model and should not be used as an actual foundation diagram for an antenna installation.

CAUTION: The foundation design shown in Figure 22 does not represent an appropriate design for any specific locality since soil conditions vary and may not meet the design criteria given in this document. Consult a local professional engineer to determine the soil conditions and appropriate foundation.

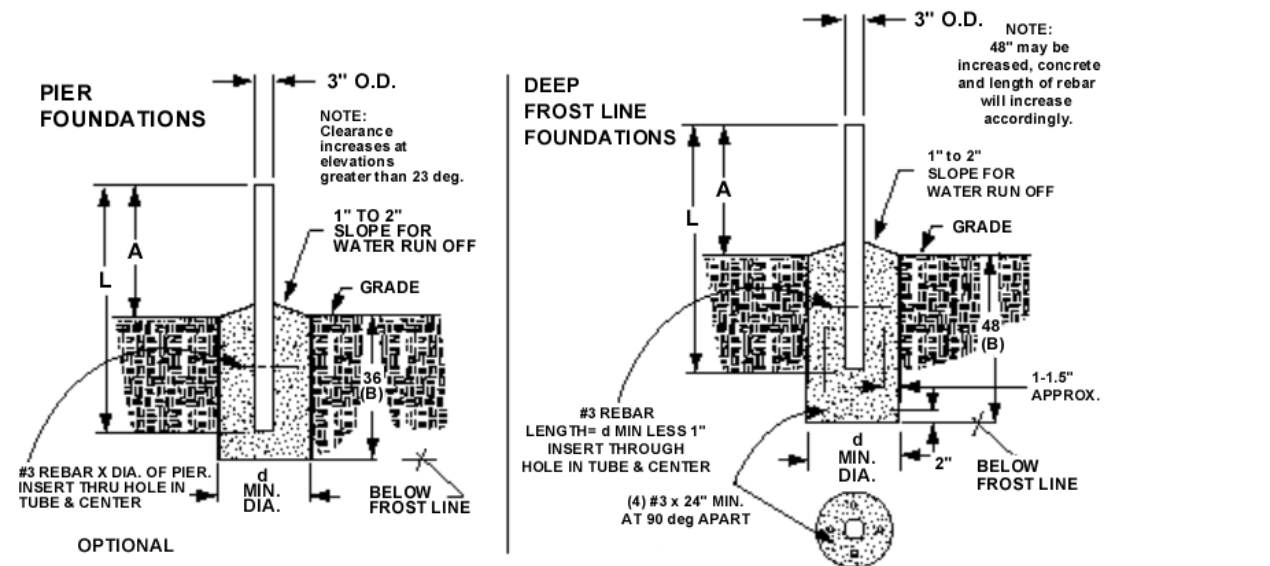

Foundation Diagram
Figure 22



INSTALLATION MANUAL
Typical Antenna

4.3 1.2-Meter ChannelMaster Antenna Assembly

This section covers the installation of the SMC 1.2-Meter ChannelMaster antenna system with AZ/EL housing and dual Ku polarity feed horn & combiner.

Table 7 lists the tools that the Field Service Engineer should have on hand. Table 8 lists the equipment that should be included in the delivered installation package.

TOOLS			
Felt Marker	Precision Inclinator	10 mm Nut Driver	3/4" Deep Socket - 1/2" Drive
Tape Measure	9" Magnetic Level	7/16 Nut Driver or Wrench	13 mm Box Open End Wrench
Torque Wrench	#2 Philips Screwdriver	Ratchet Wrench - 1/2" Drive	
Compass	3/4" Socket - 1/2" Drive	13 mm Socket - 1/2" Drive	

Field Service Tools
Table 7

Part No.	Qty	Description
1	4	Round Head Bolt with Square Neck M8 x 60 mm
2	7	Lockwasher M8 5/16"
3	7	Hex Nut M8 X 60 mm
16	1	AZ/EL Housing
17	5	Flatwasher M8 5/16"
18	1	Hex Bolt M8 x 130 mm
19	2	Round Head Bolt with Square Neck M8 x 20 mm
20	3	Round Head Bolt with Square Neck M8 x 35 mm
21	1	Weldment Clamp 3" Outer Diameter
22	1	Abrasive Pad
23	5	Azimuth Locking Bolts
24	1	Special Swivel Nut
25	1	Pointer
26	1	Spherical Washer
4	1	Bottom Feed Leg
5	1	SMC Reflector
6	2	Side Feed Leg
7	4	Hex Bolt M6 x 30 mm
8	2	Flatwasher 1/4" x 7/8"
9	1	Junction Block
10	2	Flatwasher 1/4" x 3/4" Outer Diameter
11	1	Half Junction Clamp
12	2	Bolt M6 x 20 mm
13	2	Flatwasher M6 x 1/2" Outer Diameter
14	1	Ku-Feed Wideband Assembly
15	1	Self-tapping Screw M6

1.2-Meter Antenna Assembly Installation Equipment
Table 8



4.3.1. 1.2 ChannelMaster Antenna Assembly Instructions

This section shows the steps required to assemble the 1.2 ChannelMaster antenna. The part numbers are shown in parentheses.

The AZ/EL housing (16) is installed on a 3" outer diameter ground tube, roof, or wall mount depending on the installation requirements. The appropriate load mount must be fully assembled and in place before installing the reflector and back structure.

The AZ/EL housing assembly is factory pre-assembled. However, it is not pre-configured for the required elevation angles of the satellite of interest. An exploded diagram of the AZ/EL housing is shown in Figure 23.

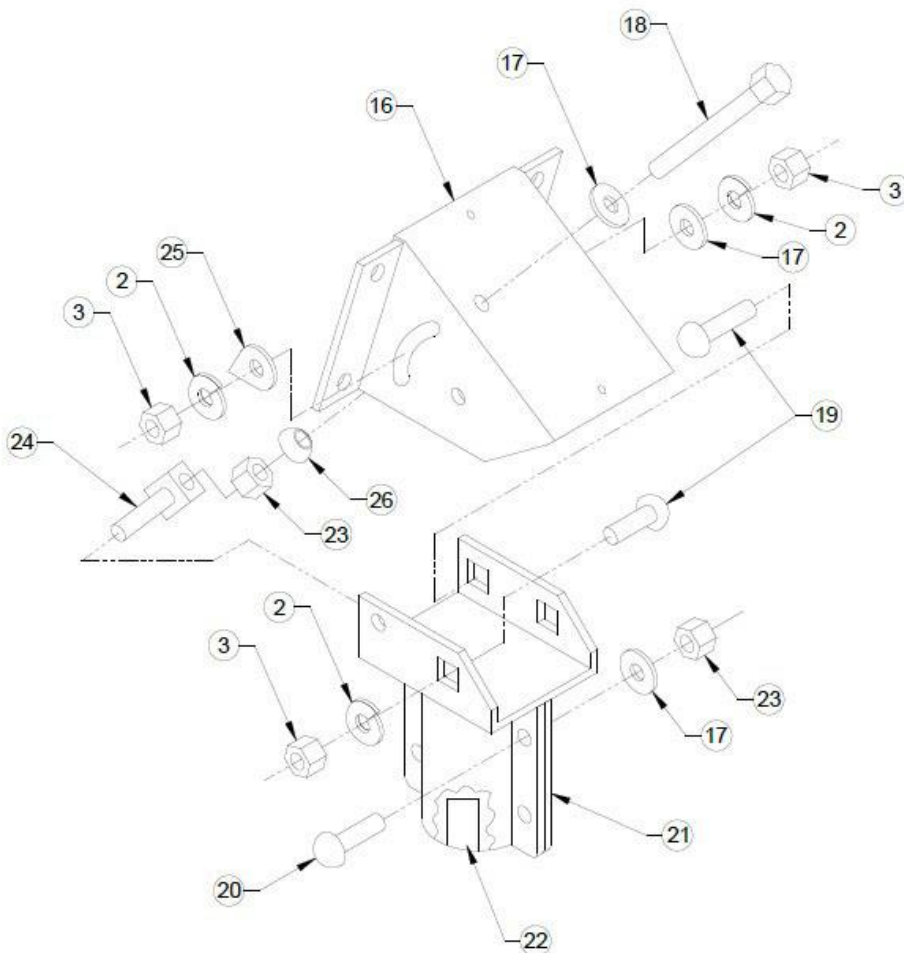

AZ/EL Housing Exploded Diagram
Figure 23



INSTALLATION MANUAL Typical Antenna

1. Loosen the elevation adjustment (18) and pivot nuts (3) (see Figure 23). Attach the reflector (5) to the AZ/EL housing (16) by inserting four M8 x 60 mm carriage bolts (1) into the four holes in the front of the reflector. The bottom feed leg hole must be located on the bottom as shown in Figure 24. Install the M8 5/16" lockwashers (2) and M8 x 60 hex nuts (3) on the bolts. Place the lockwashers next to the hex nuts. Tighten and torque to 11 ft.-lbs. Be sure not to over tighten.

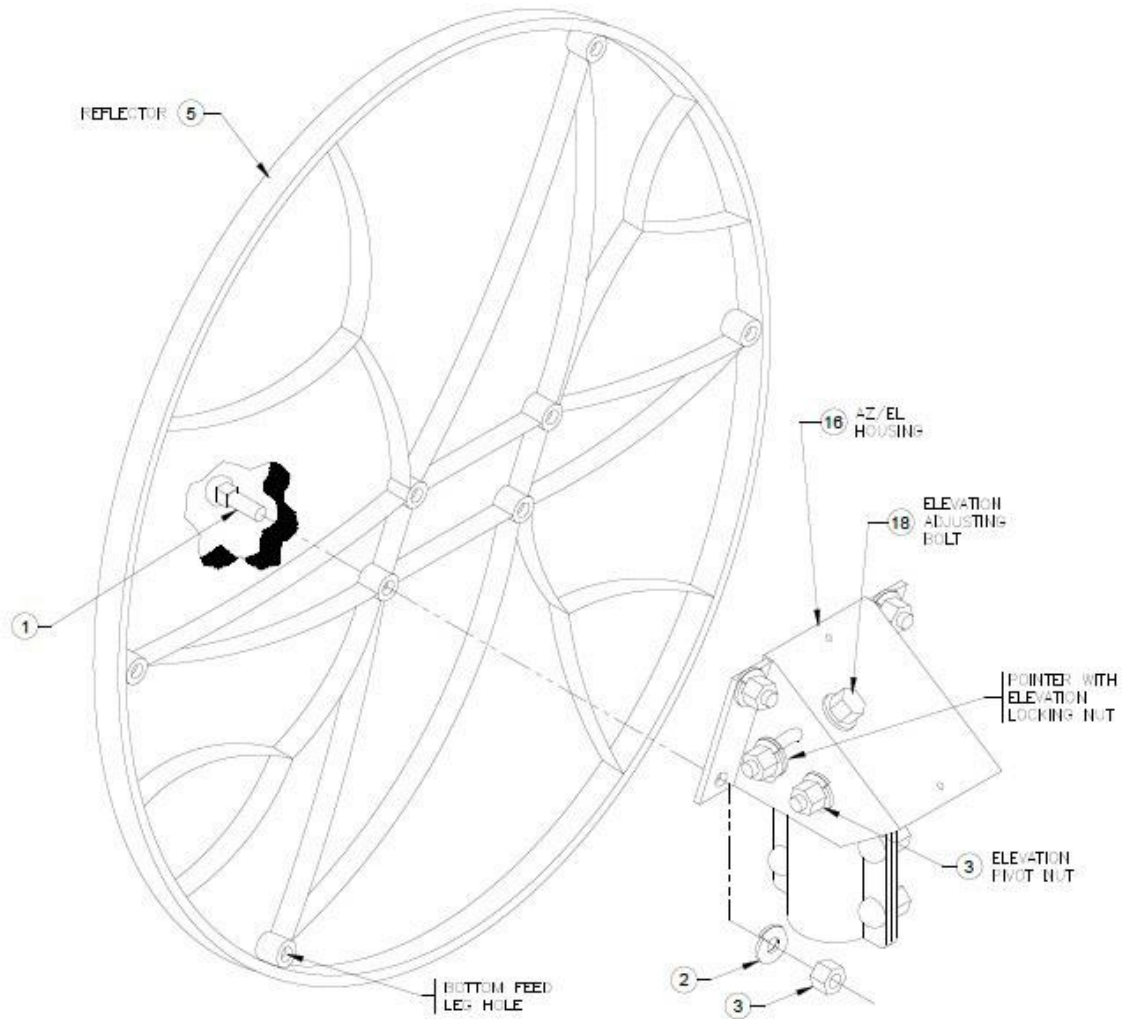

1.2-Meter Reflector Assembly
Figure 24



INSTALLATION MANUAL Typical Antenna

- Pick up the reflector with the attached AZ/EL housing assembly (16) and slide the housing onto the mount tube (see Figure 25). Swivel the antenna assembly until the reflector faces the satellite of interest. Tighten the pre-assembled azimuth locking nuts (23) so that the antenna assembly is held stationary on the tube, but can swivel freely with slight pressure.

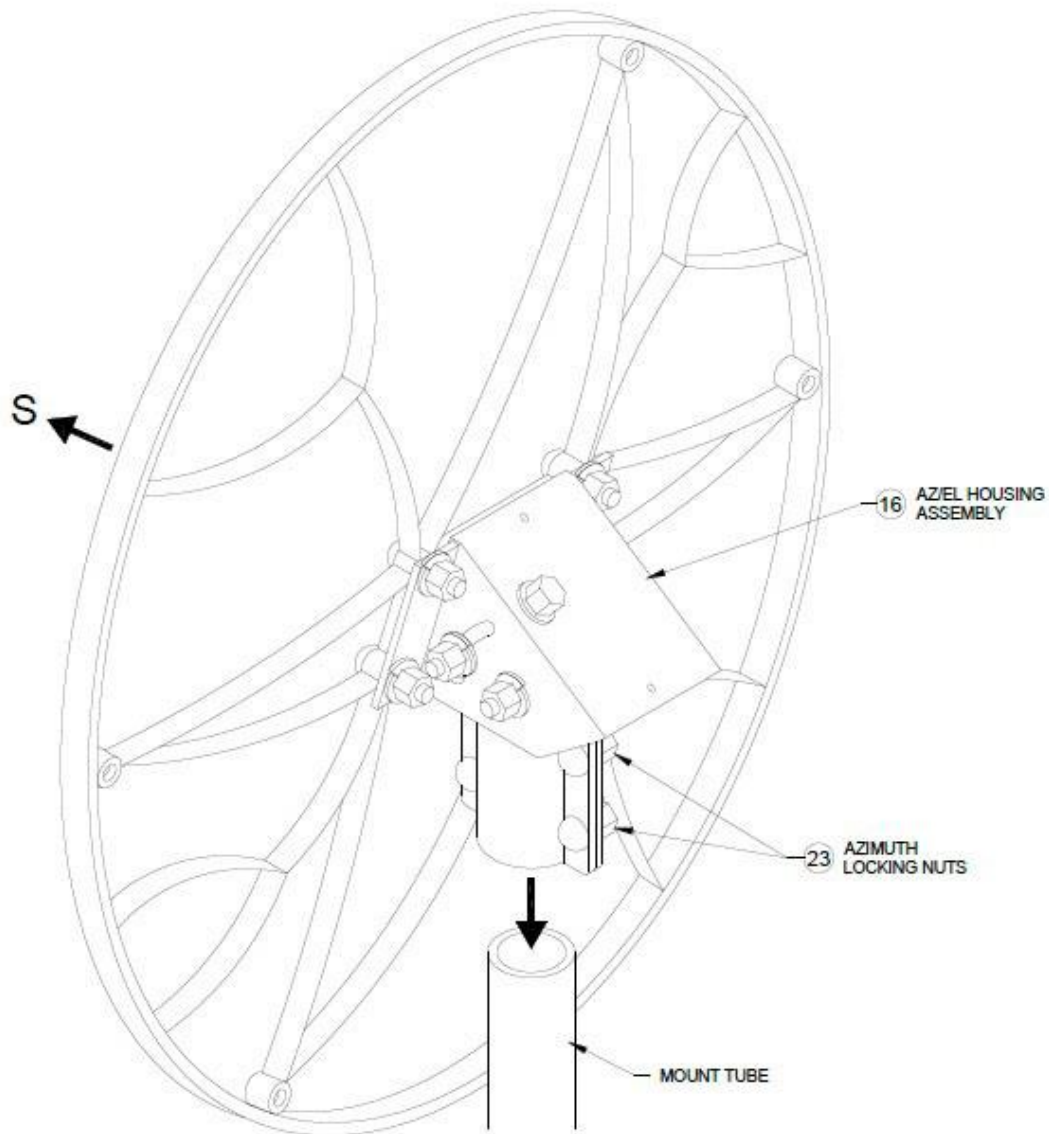

AZ/EL Assembly
Figure 25



INSTALLATION MANUAL Typical Antenna

3. Assemble the feed legs to the reflector by performing the following steps detailed in Figure 26.
 - a) Insert the bottom feed leg (4) into the hole in the bottom edge of the antenna. The bottom feed leg is the one with a slight bend on one end of the leg, a lance on the opposite end, and is shorter than the two side feed legs (6). Secure with the self-tapping screw M6 (15), but do not tighten.
 - b) Insert the two side feed legs (6) into the front of the antenna. From the back of the antenna, secure the two side feed legs (6) with the M6 x 30 mm hex bolts (7) and 1/4" x 7/8" flatwashers (8). Do not tighten.

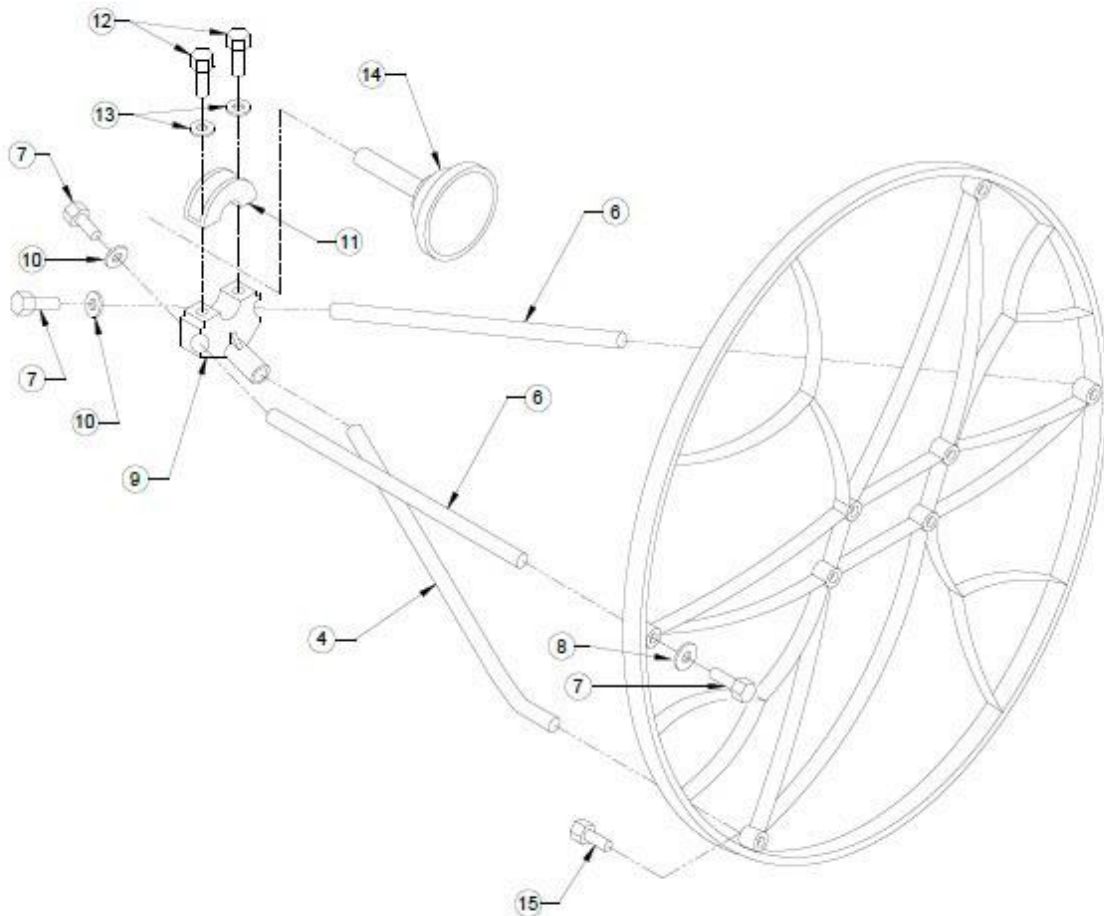

Feed & Strut Assembly
Figure 26



INSTALLATION MANUAL Typical Antenna

4. Insert the bottom feed leg (4) into the hole in the center of the junction block (9) until the lance on the leg is engaged (see Figure 26).

Note: The junction block is packed with the feed assembly.

5. Insert the side feed legs (6) into the junction block (9) and secure using the supplied M6 x 30 mm hex bolts (7) and 1/4" x 3/4" flatwashers (10). Do not tighten.
6. Once all support legs are securely in place, tighten and torque all side feed leg bolts securing the side legs to the junction block and to the antenna to 4 ft.-lbs. Tighten the supplied self-tapping screw (15) with the bottom feed leg. Make sure that the screw engages the hole in the leg.
7. The feed assembly is a dual Ku linear polarized corrugated wideband feed (14). With the feed support installed, slip the feed horn into the saddle of the junction block (9). Insert the half junction clamp (11) over the feed throat and clamp together using the M6 x 20 bolts (12) and M6 x 1/2" flatwashers (13) (see Figure 26). Install the dual port transition so the feed cover will mate over the cover plate to house the LNB's.
8. Install the LNB's onto the elbows using a small Phillips head screwdriver. Always use the rubber "O"-ring for waterproofing reasons (see Figure 27). Dielectric grease should be used to lubricate the "O"-ring. Excess grease should be removed.

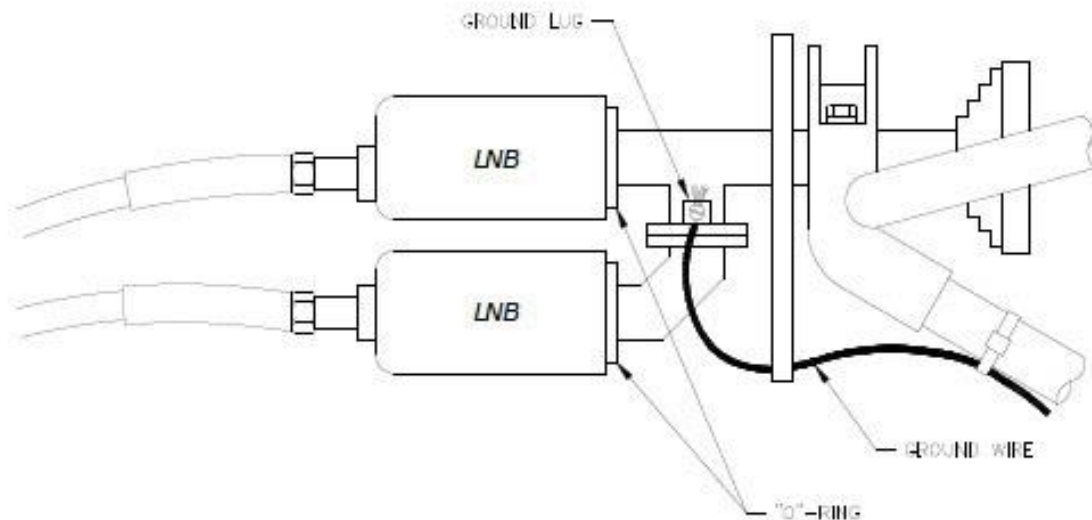

LNB Assembly
Figure 27



INSTALLATION MANUAL

Typical Antenna

4.4 1.8-Meter ChannelMaster Antenna Assembly

This section covers the installation of the SMC 1.8-Meter ChannelMaster antenna system with AZ/EL backfeed assembly and dual Ku polarity feed horn & combiner.

Table 9 lists the tools that the Field Service Engineer should have on hand. Table 10 lists the equipment that should be included in the delivered installation package.

TOOLS			
Felt Marker	Precision Inclinometer	10 mm Nut Driver	3/4" Deep Socket - 1/2" Drive
Tape Measure	9" Magnetic Level	7/16 Nut Driver or Wrench	13 mm Box Open End Wrench
Torque Wrench	#2 Philips Screwdriver	Ratchet Wrench - 1/2" Drive	
Compass	3/4" Socket - 1/2" Drive	13 mm Socket - 1/2" Drive	

Field Service Tools
Table 9

P/N	Qty	Description
1	4	Round Head Square Neck Bolt 1/2" x 3.75"/4.0" (M8 x 60 mm)
2	6	Lockwasher 1/2"
3	6	Hex Nut 1/2"
4	1	Cotter Pin 1"
5		N/A
6	1	Pointer
7	1	AZ/EL Backframe Assembly
8	1	Flatwasher 1/2"
9	1	Special Hex Head Screw 1/2" x 7"
10	1	Spherical Washer
11	1	Castle Nut 1/2"
12	1	Swivel Nut 1/2"
13	1	Flange Nut 1/2"
14	1	Round Head Square Neck Bolt 1/2" x 1 1/4"
15	4	Hex Head Bolt 1/2" x 1 1/4"
16	1	Yoke Cap Assembly
17	1	Hex Lock Nut 1/2"
18	2	Round Head Square Neck Bolt 1/2" x 1 1/2"
25	1	Ku-Feed Wideband Assembly
26	2	Hex Head Bolt M6 X 20mm
27	2	Flatwasher M6
28	1	Half Junction Clamp
29	1	Junction Block
30	2	Side Feed Leg
31	2	Hex Head Bolt M6 X 30mm
32	4	Flatwasher 1/4" x 3/4" Outer diameter
33	1	Bottom Feed Leg
34	2	Hex Bolt 1/4" x 3/4"
35	4	Lockwasher 1/4"
36	4	Hex Nut 1/4"
37	1	Antenna (SMC) Offset 1.8-meter
38	2	Round Head Square Neck Bolt 1/4" x 3/4"
39	1	Bottom Feed Leg Clamp

1.8-Meter Antenna Assembly Installation Equipment
Table 10



4.4.1. 1.8 ChannelMaster Antenna Assembly Instructions

This section shows the steps required to assemble the 1.8 ChannelMaster antenna. The part numbers are shown in parentheses.

The AZ/EL backframe assembly (7) is installed on a 4.5" outer diameter ground tube, roof, or wall mount depending on the installation requirements. The appropriate load mount must be fully assembled and in place before installing the reflector and back structure.

The AZ/EL backframe assembly is factory pre-assembled. However, it is not pre-configured for the required elevation angles of the satellite of interest. An exploded diagram of the AZ/EL backframe assembly is shown in Figure 28.



INSTALLATION MANUAL
Typical Antenna

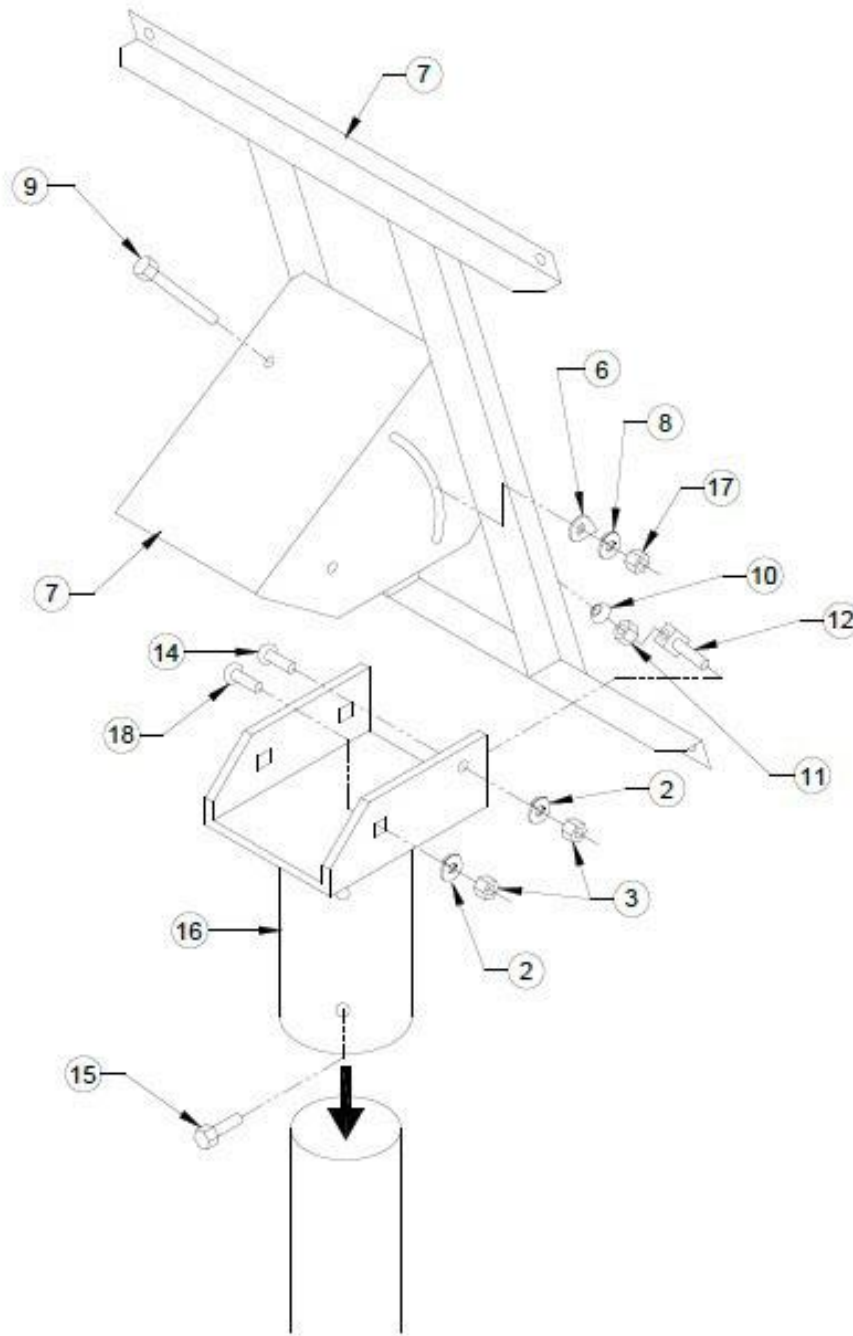

AZ/EL Backframe Assembly Exploded Diagram
Figure 28



INSTALLATION MANUAL Typical Antenna

1. Loosen, but do not remove, the four azimuth locking bolts (15) on the AZ/EL backframe assembly (7). Slide the assembly onto the mount tube (see Figure 29). Temporarily tighten one of the azimuth locking bolts to hold the assembly in place while installing the antenna.
2. Loosen the elevation locking nut (3) one full turn and the elevation pivot nut (3) a quarter turn (see Figure 29). Turn the elevation adjusting bolt counterclockwise and increase the elevation setting to approximately 50 to 60 degrees. All bolts will be tightened during the antenna pointing procedure.

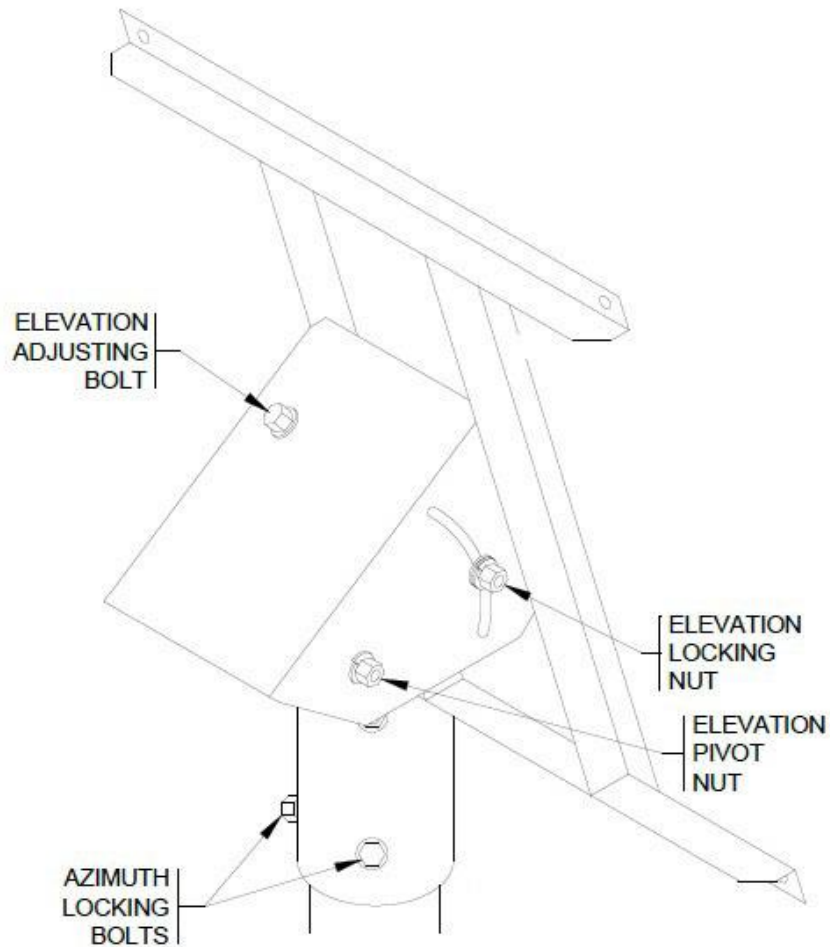

AZ/EL Backframe Assembly
Figure 29



INSTALLATION MANUAL

Typical Antenna

- Attach the reflector (37) to the AZ/EL backframe assembly (7) by inserting four M8 x 60 mm carriage bolts (1) into the four holes in the front of the reflector (see Figure 30). The arrow on the back of the reflector must be pointed up as shown in Figure 31. Install the 1/2" lockwashers (2) and 1/2" hex nuts (3) on the bolts. Place the lockwashers next to the hex nuts. Tighten and torque to 20 ft.-lbs. Be sure not to over tighten.

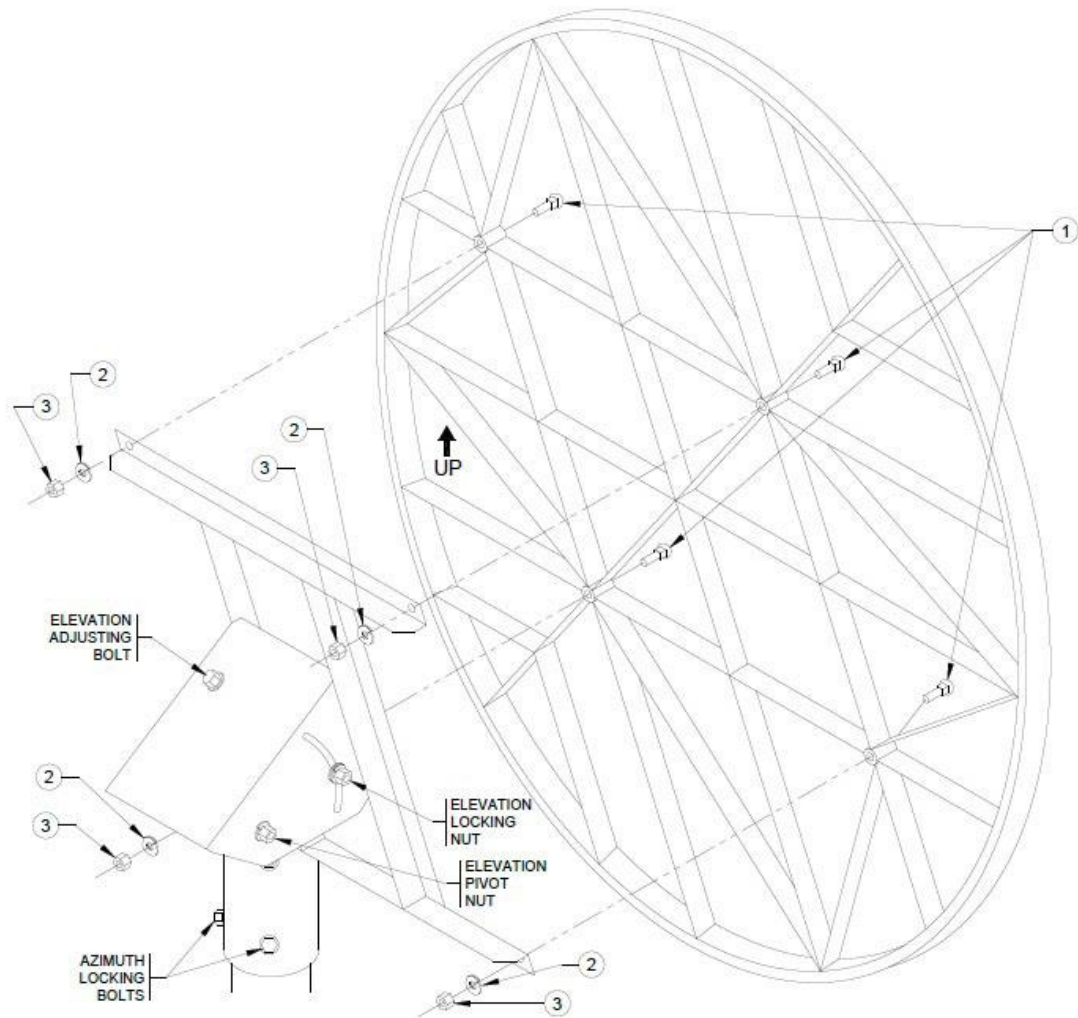

1.8-Meter Antenna Assembly
Figure 30



INSTALLATION MANUAL Typical Antenna

4. Assemble the feed legs to the reflector by performing the following steps detailed in Figure 31.
- c) Insert the bottom feed leg (33) (alignment hole end) into the bottom feed leg clamp (39) and align the alignment hole in the bottom feed leg with the alignment pin inside the clamp. The bottom feed leg is the one with a lance on one end and an alignment hole on the opposite end. Install the bottom feed leg with clamp onto the bottom edge of the antenna and secure with two 1/4" x 3/4" bolts (34), 1/4" lockwashers (35), and 1/4" hex nuts (36). Do not tighten.
 - d) Attach the two side feed legs (30) to the sides of the antenna. Secure the side feed legs with the 1/4" x 3/4" hex bolts (34), 1/4" flatwashers (32), 1/4" lockwashers (35), and 1/4" hex nuts (36). Do not tighten.

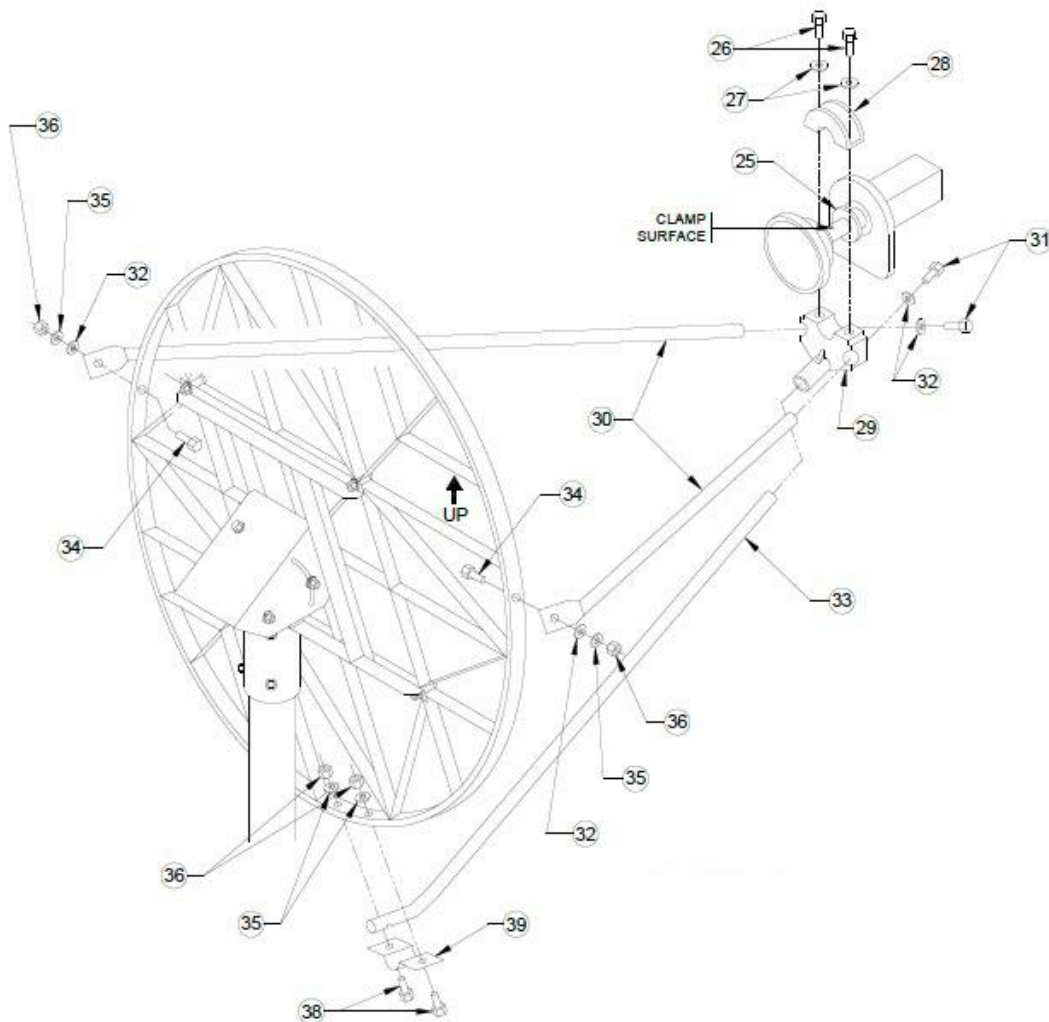

Feed & Strut Assembly
Figure 31



INSTALLATION MANUAL Typical Antenna

5. Insert one side feed leg (30) into the junction block (29) and secure using the supplied M6 x 30 mm hex bolt (31) and 1/4" x 3/4" flatwasher (32). Do not tighten.

Note: The junction block is packed with the feed assembly.

6. Insert the bottom feed leg (33) into the hole in the center of the junction block (29) until the lance on the leg is engaged (see Figure 31).
7. Insert the other side feed leg (30) into the junction block (29) and secure using the supplied M6 x 30 mm hex bolt (31) and 1/4" x 3/4" flatwasher (32). Do not tighten.
8. Once all support legs are securely in place, tighten and torque all side feed leg bolts securing the side legs to the junction block and to the antenna to 4 ft.-lbs.
9. The feed assembly is a dual Ku linear polarized corrugated wideband feed (25). With the feed support installed, slip the feed horn into the saddle of the junction block (29). Insert the half junction clamp (28) over the feed throat and clamp together using the M6 x 20 bolts (26) and M6 flatwashers (27) (see Figure 31). Install the dual port transition so the feed cover will mate over the cover plate to house the LNB's.
10. Install the LNB's onto the elbows using a small Phillips head screwdriver. Always use the rubber "O"-ring for waterproofing reasons (see Figure 32). Dielectric grease should be used to lubricate the "O"-ring. Excess grease should be removed.

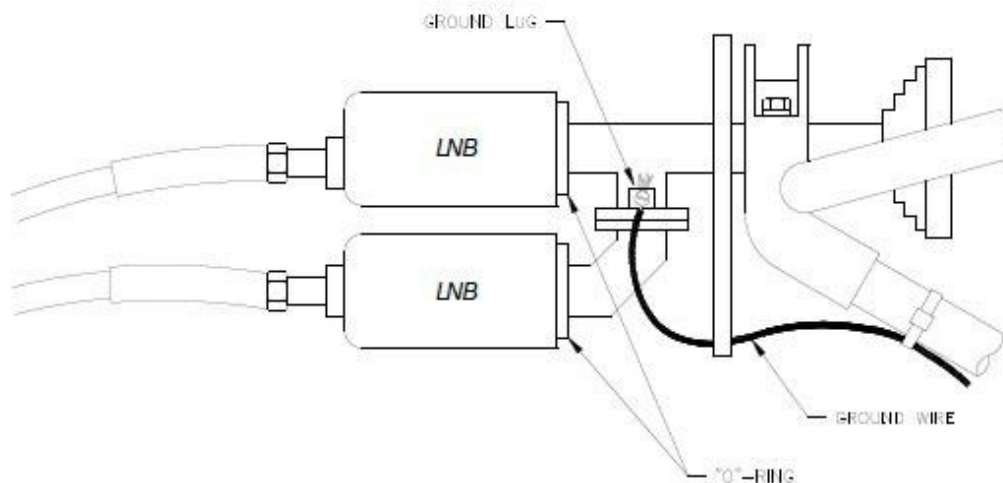

LNB Assembly
Figure 32



4.5 Antenna Pointing and Peaking

This section details the procedures required to align the antenna with the satellite of interest.

Alignment with the satellite is obtained by setting the polarization, elevation, and azimuth. The elevation and azimuth values are calculated based on the site latitude, longitude, and orbital slot. The information needed to complete the calculations is included in the project documentation.

Given the antenna latitude, longitude, and satellite longitude (over the equator), the following calculations can be made (north of the equator):

$$AZ = 180^\circ + \arctan(\tan \theta / \sin \alpha)$$

$$EL = 90^\circ - T - R$$

Where

AZ = True Azimuth to view satellite, in degrees east (CW) of True North.

α = Antenna latitude in degrees

θ = Satellite longitude minus antenna longitude in degrees

Where

EL = True elevation angle to view satellite in degrees

R = $\arccos(\cos \theta \cos \alpha)$

T = $\arctan[\sin R / (6.6166 - \cos R)]$

Note: Longitude values are positive for antenna sites or satellite positions west of GMT and negative east of GMT.

Preliminary Setup

It is very important that you perform the following steps to align the mount squarely on the mast to prevent tilting during alignment. Failure to do this will make peaking the elevation and azimuth very difficult

1. Loosen all four azimuth locking bolts.
2. Simultaneously snug-tighten both top bolts to an equal depth, then 1/8 turn, centering the cap on pole.
3. Repeat Step 2 for bottom bolts.



INSTALLATION MANUAL Typical Antenna

Polarization of the Feed

Polarization of the feed is obtained by using a 10mm nut driver to loosen the two clamp bolts and then turning the feed. Align the alignment mark on the half junction clamp (28) with the "0" (zero) mark on the feed horn scale (see Figure 33). Turn the feed assembly clockwise or counter clockwise to obtain the correct polarization setting for your location. Make sure the half junction clamp is installed with the arrow pointed toward the antenna as shown in Figure 33. Torque the bolts securing the half junction clamp to the junction block to 4 ft-lbs. maximum.

Note: The Vertical Downlink Polarity is the long dimension of the rectangular port on the LNB when the transition is in a vertical position. Horizontal Downlink Polarity is the long dimension of the rectangular port on the LNB when the transition is in a horizontal position.

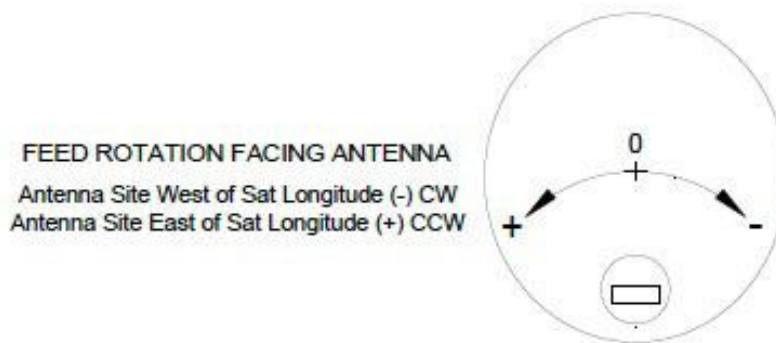

Polarization of the Feed
Figure 33

Elevation

Loosen the elevation locking bolt/nut and elevation pivot bolt/nut 1/4 turn (see Figure 34). Turn the elevation adjustment bolt clockwise to decrease elevation or counterclockwise to increase elevation. Align the pointer with appropriate mark at the desired elevation reading. This will be an approximate coarse setting. The optimum setting will be achieved when fine-tuning.

Note: It is important to note that the degree values shown on the elevation scale are Beam, i.e., when the antenna face is vertical, the mechanical elevation is 0°, but the Beam Elevation (signal) is 22.6°.



INSTALLATION MANUAL
Typical Antenna

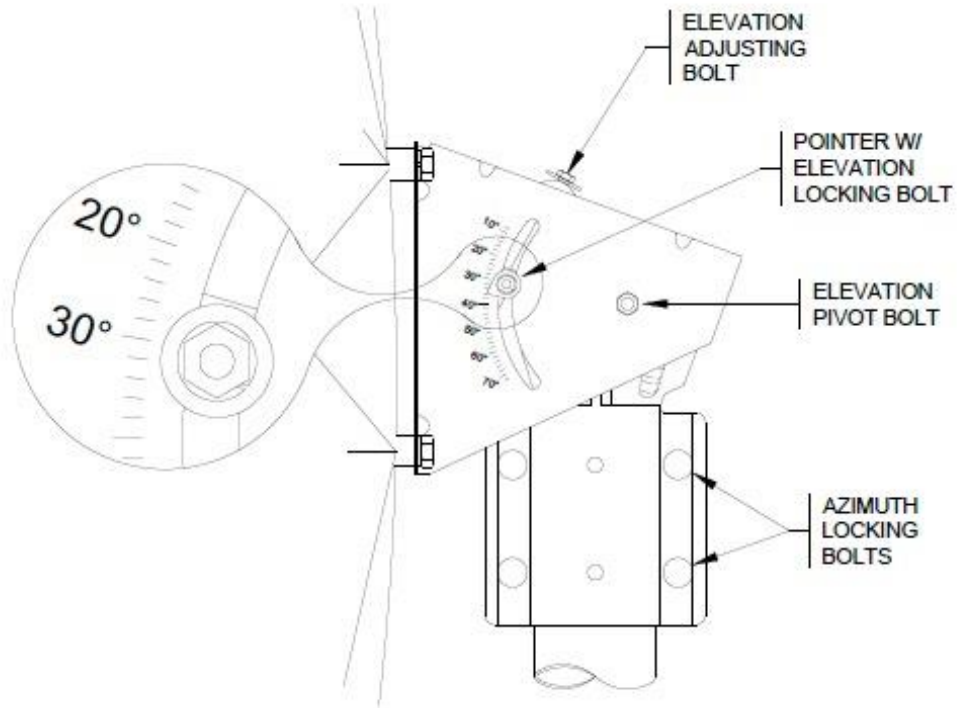

Elevation Adjustment
Figure 34



Azimuth

This section gives a relatively easy method of adjusting the four azimuth locking bolts without tilting the AZ/EL housing/backframe assembly on the mast tube (see Figure 35). Tilting makes the azimuth and elevation adjustments difficult. Also, be cautious not to over tighten bolts at any time prior to lockdown because scarring the mast tube will make the fine tune adjustment process difficult.

Begin by loosening the top and bottom azimuth locking bolts 1/8 turn. Minimum loosening will allow azimuth rotation on the pole without tilting. Next, rotate the antenna and AZ/EL housing/backframe assembly to the correct compass reading for your location and satellite. Slowly sweep the antenna from left to right until the signal is found. If the desired signal is not found, increase or decrease the elevation setting and repeat the azimuth sweep.

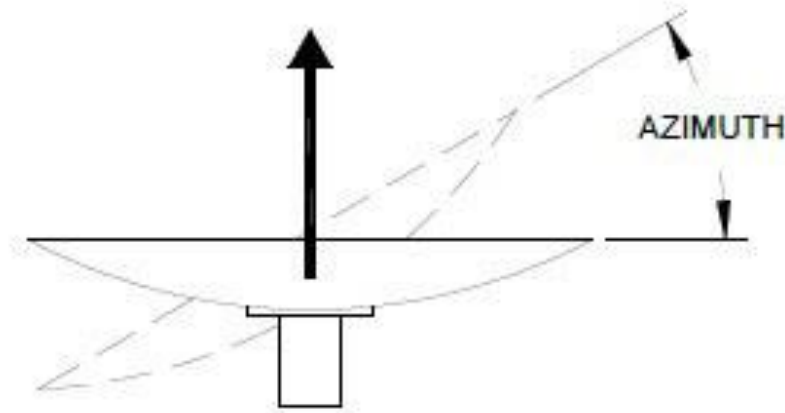

Azimuth Adjustment
Figure 35

Fine Tuning

Use a spectrum analyzer for final adjustments to obtain the maximum antenna performance. Alternate between elevation and azimuth to fine-tune the adjustments until signal improvement can no longer be detected. Once peaked, tighten all hardware.

Final Lock Down

Tighten progressively (1/8 turn each) all four azimuth locking bolts. Repeat until 85-95 ft-lbs. torque is reached. Tighten all remaining hardware. The torque for M8 round head square neck bolts is 11 ft-lbs.

Figure 34 depicts a typical mechanical pointing system frequently found on many ChannelMaster Antennas. When pointing any antenna, accuracy is best achieved using an inclinometer or pointing tool



4.6 Connector Installation

This section details the procedures for installing the connectors.

Connector Kit Contents	Qty
PAN-TY Weather Resistant Cable Tie 9.7"	25
23 Rubber Splicing Tape 1" x 20'	1
EPS300 Adhesive Lined shrink tube 2' x 3/4"	8
Super 88 Vinyl Electrical Tape 3/4" x 44'	1
Dielectric Grease Tube	1
RG11 Plenum Connectors	5
RG11 Non-Plenum Connectors	5
Gas Tube Arrestors	2
RG11 Non-Plenum Cable	AR
RG11 Plenum Cable	AR

Connector Kit Contents
Table 11

Connector Tools
Canare Non Plenum Crimpers
Plenum Crimpers
Heat Gun
Wire Cutting Dykes
Razor Knife

Connector Tools
Table 12

1. Begin with a clean and straight cut edge of RG11. Using a razor knife with the blade edge facing your thumb, trim the cable along its circumference. Cut (approximately) a 3/16" cross section of the cable cutting to, but not through, the copper ferule and taking care to avoid scoring the ferule with the blade. Move 3/16" down the length of the cable and trim off the jacket this time avoid cutting through the braid and foil (see Figure 36).

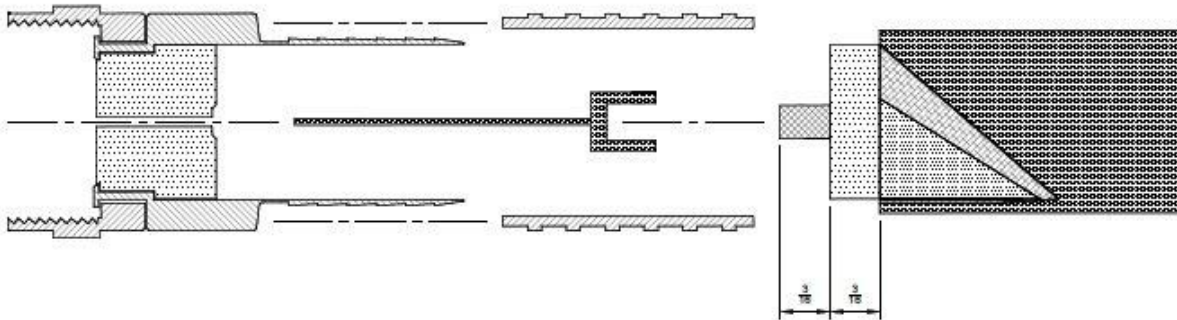

Trimming RG11 Cable
Figure 36

2. Fit the connector pin over the ferule by pushing the ferule into the correlating cavity in the pin body. If the ferule was cut properly, the pin body should just rest on the center cable dielectric foam. With the pin in place, use the crimper to crimp it in place. Take care that the pin does not shift off the ferule while doing so. Before inserting the pin, inject a small pea sized amount of the supplied dielectric grease into the base of the insertion side of the connector throat. This will reduce electrolysis corrosion due to



INSTALLATION MANUAL

Typical Antenna

moisture and DC current. Slide the crimp sleeve over the cable by taking the connector body and guiding the cable with the pin into the hole in the dielectric core of the connector body.

3. Once the pin is set, slowly insert the center (foam dielectric with foil cover) into the inside of the center throat of the connector body. Guide the outside edge of the throat between the foam and the braided shield. You should expect to insert approximately 3/8" of the dielectric into the connector body and 1/4" or more of the cable jacket over the center throat. Finally, slide the sleeve over the connector body and crimp in place using the appropriate crimpers (see Figure 37).

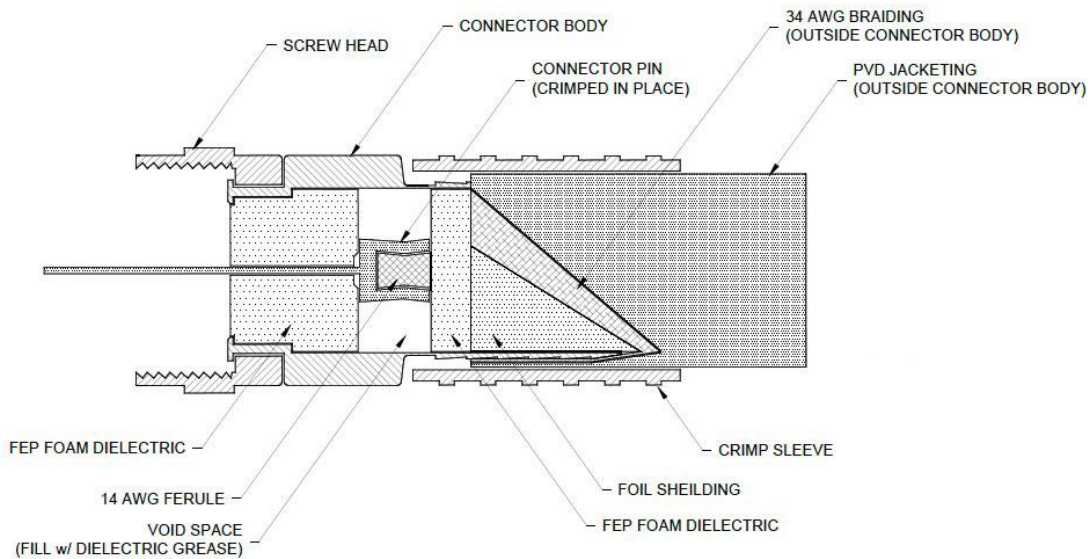

Crimping RG11 Cable
Figure 37

4. After a solid termination has been made, slide a 2" strip of shrink tube around the cable so that it covers the transition between the cable jacket and just short of the tightening nut on the connector. Using a heat gun or other appropriate source of heat, slowly heat the tube evenly so that it shrinks in place evenly and snugly. Do not overheat any part of the tubing. Always move the heat source evenly over the entire tubing. The shrink tube is adhesive lined so before shrinking the tube, be sure it will cover the critical areas as specified. When properly shrunk, the tube will have no wrinkles in its surface and its shape will have conformed to the shape of the connection (see Figure 38).



INSTALLATION MANUAL Typical Antenna

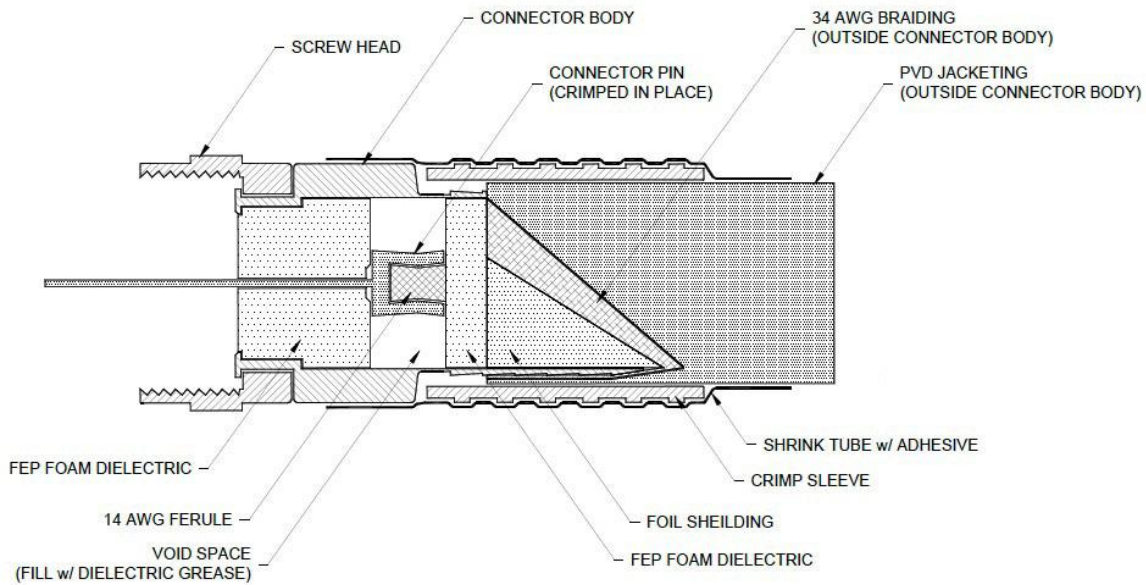

Weather Sealing RG11 Cable
Figure 38

The coax is now ready for connection to the LNB. Before connecting, be sure to read Section 4.8 Feed Cover Modification.

Place a small dab of dielectric grease on the inside of the connector. Then tighten the connector over the screw threads on the LNB using a 7/16" wrench, tightening only snugly. Do not over tighten.

With a six-inch strip of the supplied vapor tape, begin wrapping clockwise from the LNB housing while overlapping a quarter inch with each revolution. Pull the tape tightly while wrapping to create a sufficiently sealed, but not bulky layer over the connector. Stop a quarter inch past the end of the connector.

Apply a layer of vinyl tape starting where you ended with the layer of vapor tape and finishing on the LNB housing. Repeat this process on every connector exposed to harsh environmental conditions or subject to drastic temperature swings.



INSTALLATION MANUAL Typical Antenna

4.7 Feed Cover Modification

This special procedure covers the installation modifications necessary to enable the use of RG11 cable (with a maximum bend radius of 4") with the ChannelMaster feedhorn cover.

Materials Required
ChannelMaster Feed Cover
Feed Cover Screws
Infused Vapor Tape
Tie Wraps

Materials Required
Table 13

Tools Required
Electric Hand Drill
7/16" Drill Bit
Razor Knife
Screw Driver – Phillips Head

Tools Required
Table 14

Procedures



1. Drill two 5/8" holes separated by 1-3/4" on the vertical center into the closed end of the feed cover using a 7/16" drill bit. The holes must be large enough to accommodate the fully terminated cable.
2. Clean the outside edges of the drilled holes with the razor knife, scraping off any excess materials.
3. Feed the IFL cable through the drilled holes from the outside cover to the inside cover.
4. Pull a little cable slack through the cover connector and weatherproof the connection at the LNB. Ensure that there is a connection and seal.
5. Slide the feed cover over the LNB and attach it to the ground plane using the feed cover screws. The RG11 cable should not be stuffed or wound inside the feed cover.
6. With the cover firmly attached, dress the cables extending outward from the cover so that they are arranged neatly and orderly.
7. Place a tie-wrap around both cables approximately 4" out from the end of the feed cover. Tighten firmly and cut off the excess tie-wrap. Repeat this process until 16" of the cable length (measured from feed cover to entry point) are tied. This will now be the service loop.
8. Line the cable along the underside of the center feed support leg. Tie-wrap the service loop to hang freely two inches below the vertex plate.
9. Tighten the tie-wrap firmly and cut off the excess lead. Repeat this process along the length of the center feed leg, attaching ties every 8". Dress the cable so it is neat and orderly as you proceed.



4.8 Grounding

This section details the procedures required for grounding the antenna.

The load frame, antenna mount assembly, and feed cables must be grounded in accordance with current National Electric Code and local electric codes to protect the equipment from surges due to nearby lightning strikes. Figure 39 illustrates our typical method of providing a means for the client to connect the ground. The clamp provided affords a solid connection to facilitate this.

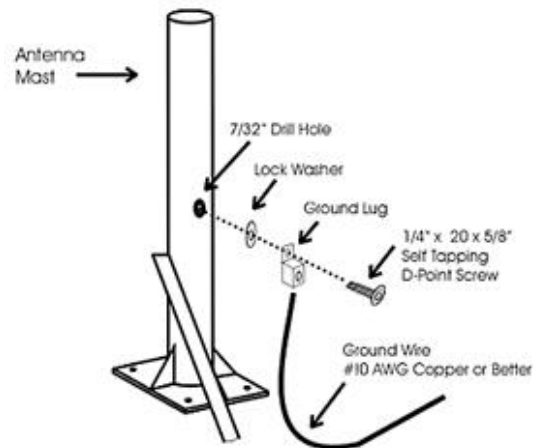

Typical Antenna Ground
Figure 39

For additional protection, Gas Tube Arrestors (GTA) may be placed inline with the coaxial cable. A ground block lug may also be added onto the arrestor. When GTA's are mounted outdoors, all connections must be protected and sealed as per standards for outdoor protection. Figure 40 shows a typical GTA installation.



Gas Tube Arrestors
Figure 40